

STL2169 - STL2169K

TELAJETTO LATERALE SPECIFICO - SPECIFIC SADDLEBAG TUBULAR HOLDER - SUPPORT TUBULAIRE POUR SACOCHES CAVALIÈRES - SPEZIAL SEITENTRAEGER FUER WEICHTASCHEN - PORTA ALFORJAS TUBULAR LATERAL - SUPORTE LATERAL DE ALFORGES

| N° | Descrizione/Description | Caratteristiche/Features | Codice/Code | Quantità/quantity |
|----|---|---|----------------------|-------------------|
| 1 | Telaio laterale - Side frame - Châssis latéral Soporte lateral - Seitenrahmen - Suporte lateral | - | STL | 2 (DX-SX) |
| 2 | Supporto laterale - Lateral support - Untere Halterung Support latéral - Soporte lateral - Suporte lateral | - | GL6469SX GL6469DX | 2 (DX-SX) |
| 3 | Vite - Screw - Vis - Schraube Tornillo - Parafuso | TSP M8x60 | 860TSP | 4 |
| 4 | Rondella - Washer - Rondelle - Scheibe Arandela - Arruela | Foro Ø10mm | 10RON | 4 |
| 5 | Dado - Bolt - Ecrou - Mutter Tuerca - Porca | Dado Autobloccante Flangiato M8 (H9,5mm) | 8DADIFN | 4 |
| 6 | Distanziale - Spacer Entretoise - Distanzstueck Distanciador - Espaçador | Ø20x20 Foro 8,5mm | C20L20F8.5ALT | 4 |
| 7 | Tappo - Cap Fiche - Stecker Enchufe - Capa | - | 13COP | 4 |
| 8 | Particolari Inclusi Nel 2169KIT Parts Included In The 2169KIT Pièces Inclues Dans Le Kit 2169KIT Im 2169KIT enthaltene Teile Piezas incluidas en el 2169KIT Peças incluídas no 2169KIT | - | - | - |

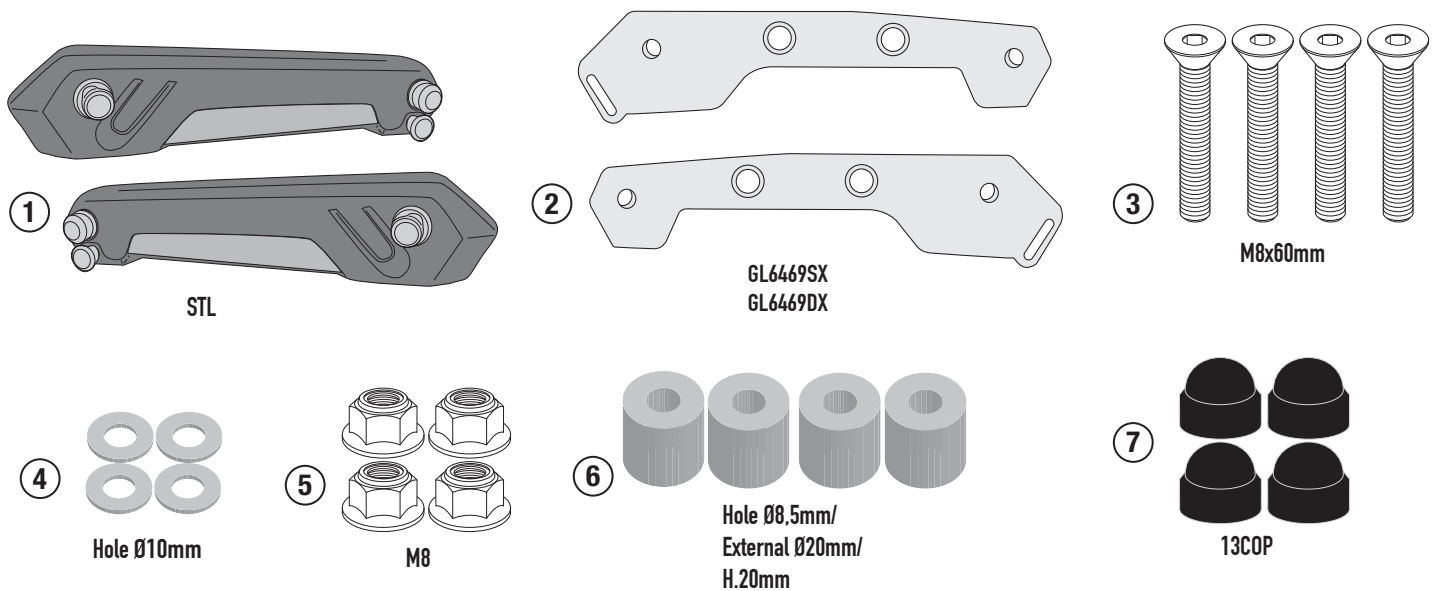

- ATTENZIONE : STRINGERE LE VITI SOLO DOPO AVER ULTIMATO IL CORRETTO POSIZIONAMENTO DEI COMPONENTI
- CAUTION : TIGHTEN THE SCREW ONLY AFTER COMPONENTS HAVE BEEN PLACED IN THEIR CORRECT POSITIONS.
- ATTENTION : SERRER LES VIS QUE LORSQUE LES COMPOSANTS ONT ÉTÉ MISES EN POSITION CORRECTE.
- ACHTUNG : SCHRAUBE ERST DANN ANZUZIEHEN, WENN DIE KOMPONENTEN POSITIONIERT SIND.
- ATENCIÓN : APRETAR LOS TORNILLOS SOLO DESPUES DE HABER ULTIMADO EL CORRECTO POSICIONAMIENTO DE LOS COMPONENTES.
- CUIDADO : APERTAR O PARAFUSO SOMENTE DEPOIS QUE COMPONENTES FORAM COLOCADOS NAS POSIÇÕES CORRETAS.

STL2169 - STL2169K

TELAIETTO LATERALE SPECIFICO - SPECIFIC SADDLEBAG TUBULAR HOLDER - SUPPORT TUBULAIRE POUR SACOCHES CAVALIÈRES - SPEZIAL SEITENTRAEGER FUER WEICHTASCHEN - PORTA ALFORJAS TUBULAR LATERAL - SUPORTE LATERAL DE ALFORGES

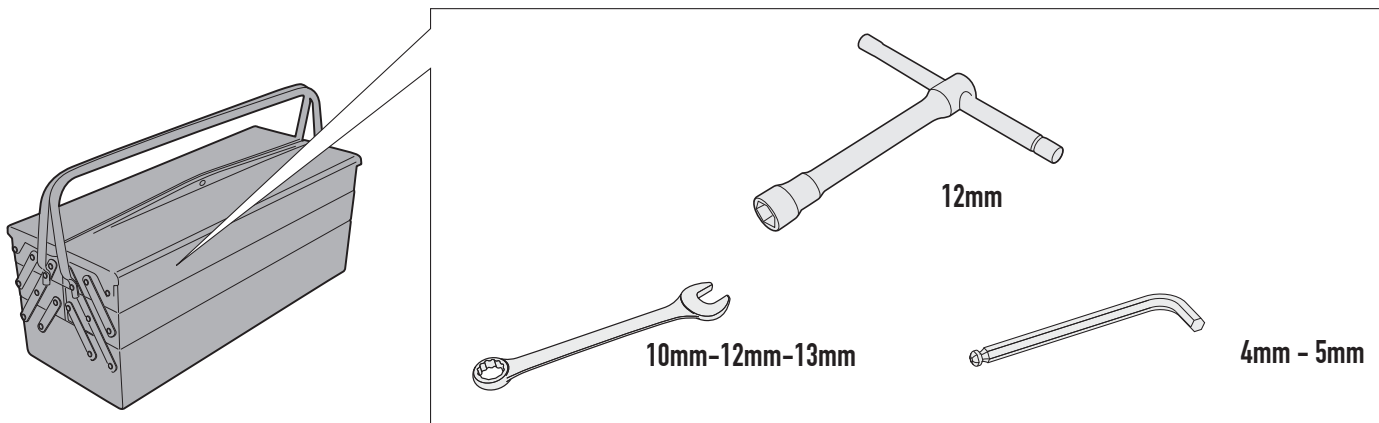
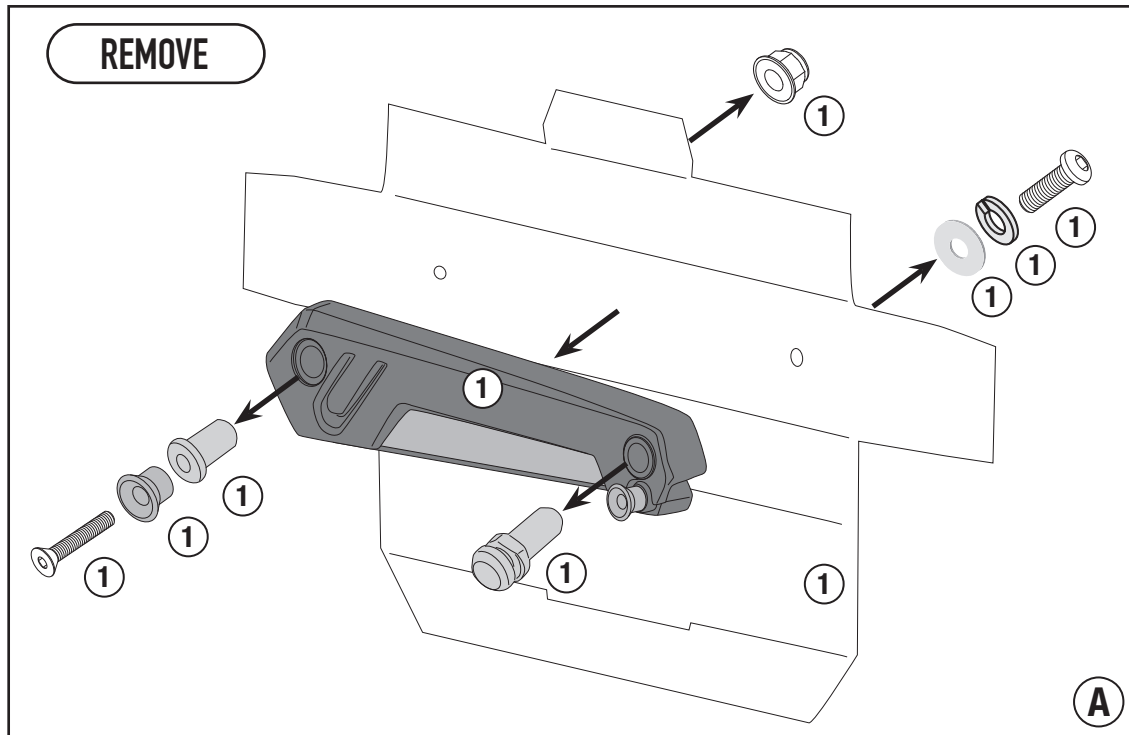

IT_ Nel caso in cui sulle viti originali sia presente del frenafili, ripristinarlo durante il montaggio dell'accessorio.

EN_ If there is threadlocker on the original screws, use threadlocker when mounting the accessory.

DE_ Falls sich auf den Originalschrauben Schraubensicherungsklebstoff befand, sollte dieser auch bei der Montage des Zubehörs wieder aufgetragen werden

FR_ Si du frein filet est présent sur les vis d'origine, l'appliquer également lors du montage de l'accessoire

ES_ En caso de que el fijador de roscas se encuentre presente en los tornillos originales, colocarlo nuevamente en el montaje del accesorio

PT_ Se houver trava rosca nos parafusos originais, inserir novamente durante a montagem do acessório



STL2169 - STL2169K

TELAIETTO LATERALE SPECIFICO - SPECIFIC SADDLEBAG TUBULAR HOLDER - SUPPORT TUBULAIRE POUR SACOCHES CAVALIÈRES - SPEZIAL SEITENTRAEGER FUER WEICHTASCHEN - PORTA ALFORJAS TUBULAR LATERAL - SUPORTE LATERAL DE ALFORGES

SR2169 + STL2169

TIGHTENING TORQUE 20Nm

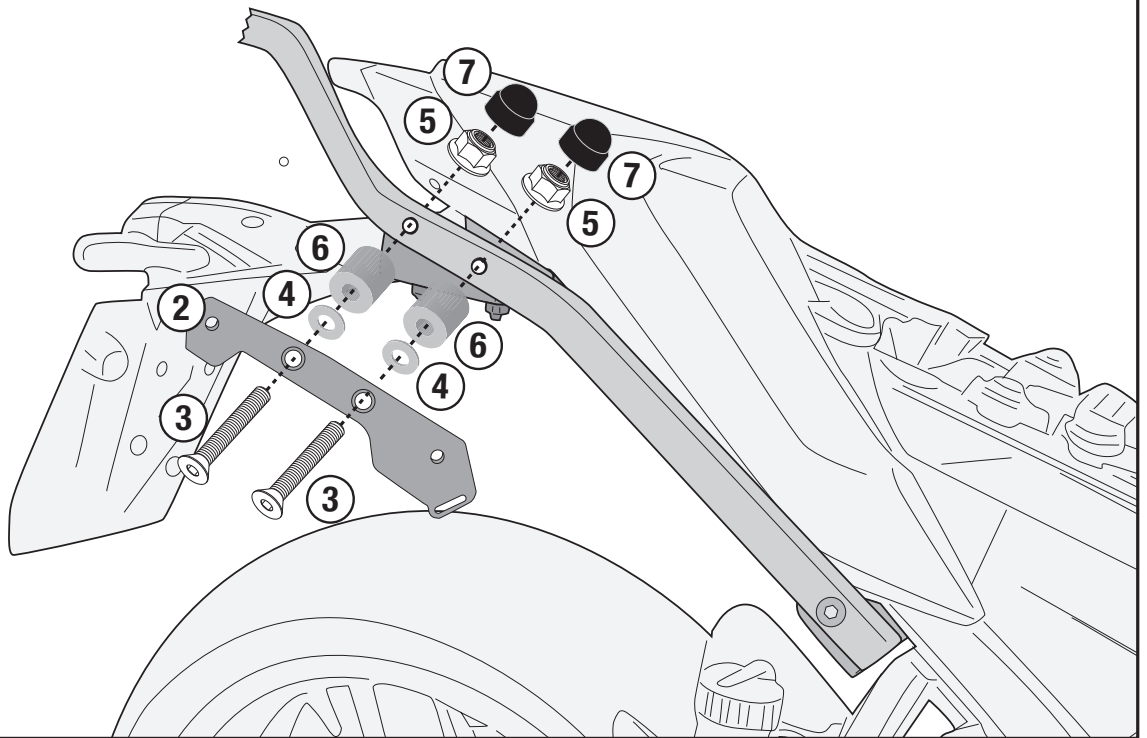

2169KIT + STL2169

TIGHTENING TORQUE 20Nm

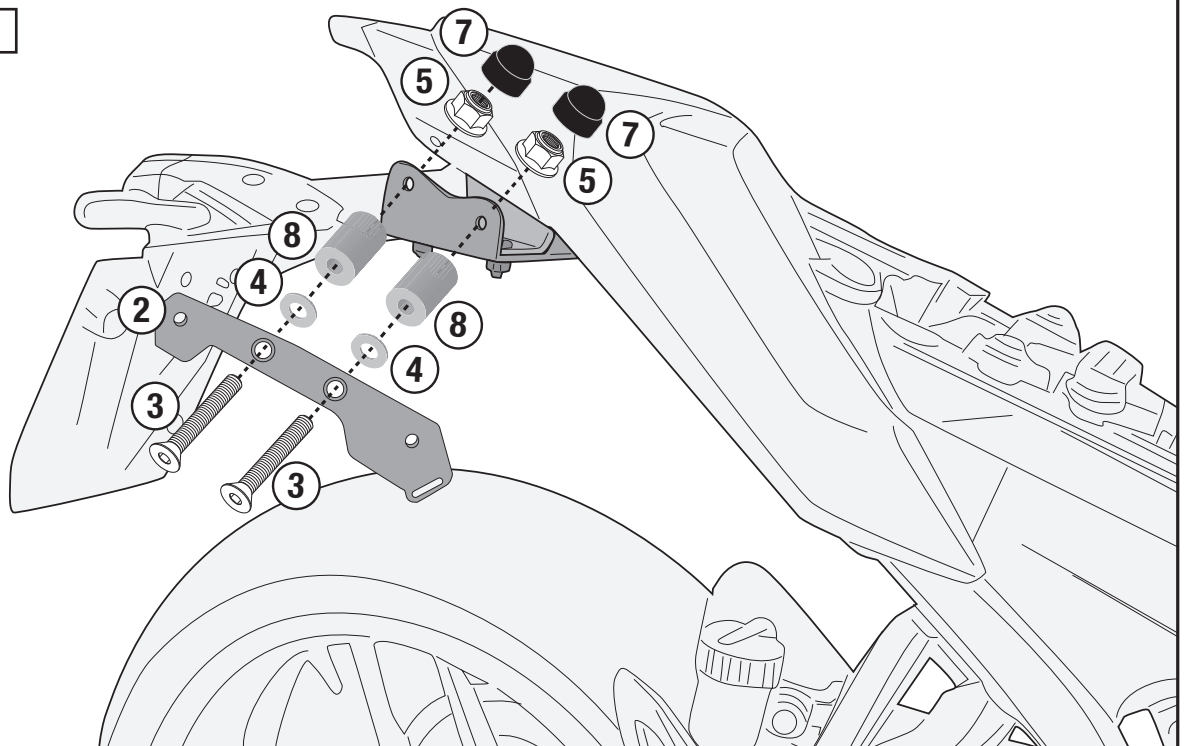

STL2169 - STL2169K

TELAIETTO LATERALE SPECIFICO - SPECIFIC SADDLEBAG TUBULAR HOLDER - SUPPORT TUBULAIRE POUR SACOCHES CAVALIÈRES - SPEZIAL SEITENTRAEGER FUER WEICHTASCHEN - PORTA ALFORJAS TUBULAR LATERAL - SUPORTE LATERAL DE ALFORGES

SR2169 + STL2169

2169KIT + STL2169

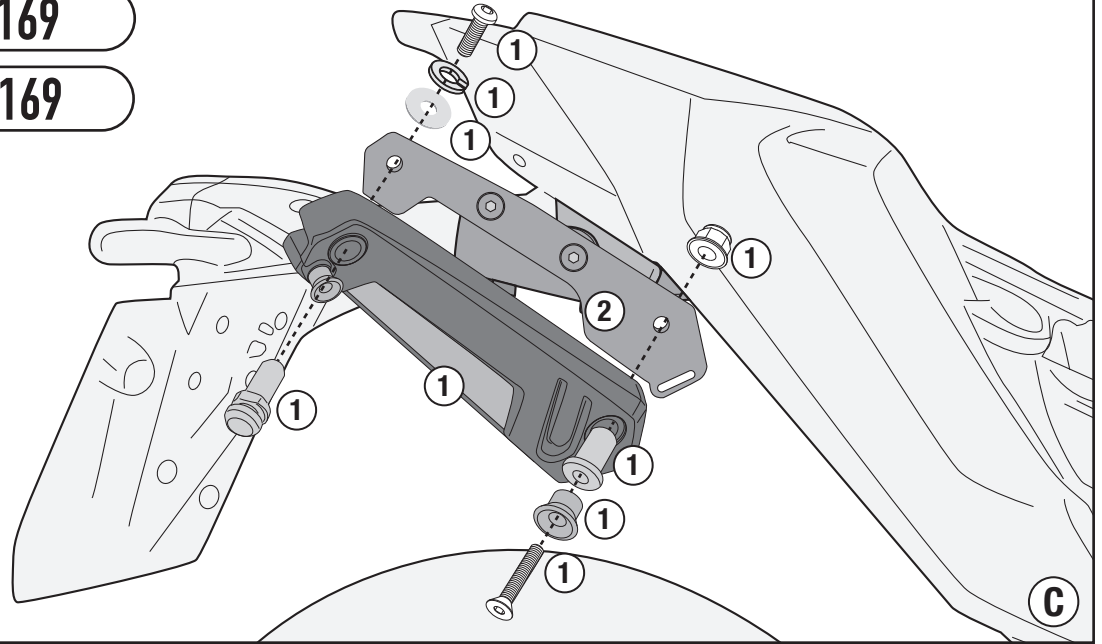

TIGHTENING TORQUE 9,5Nm

PER APRIRE / TO OPEN / ZUM ÖFFNEN / POUR OUVRIR / PARA ABRIR / PARA ABRIR

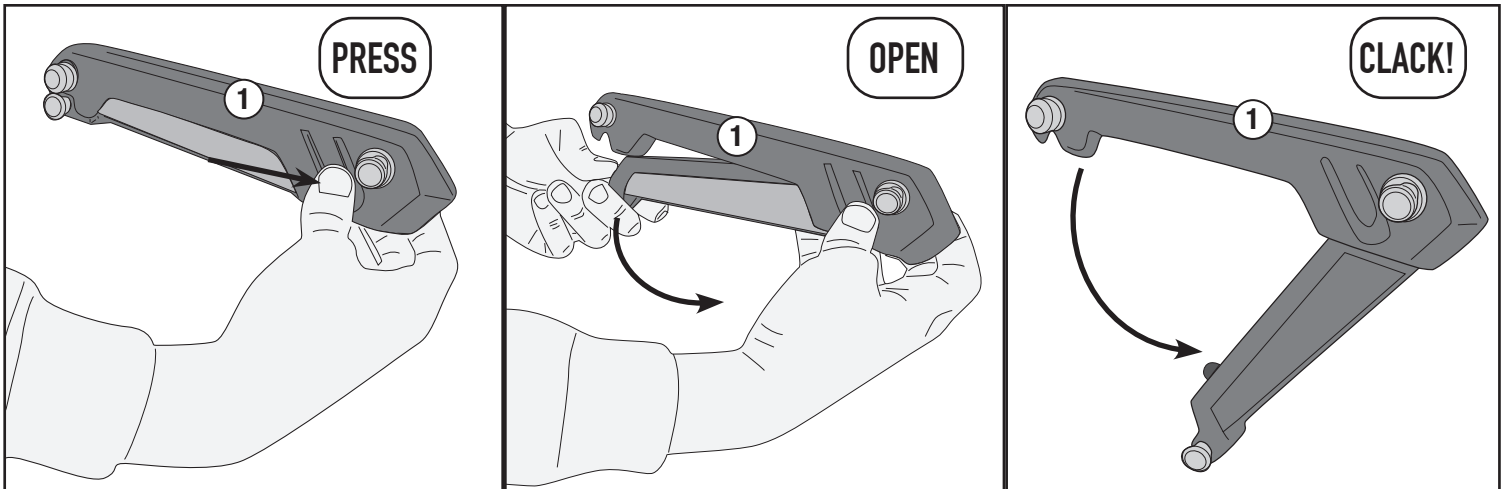

PER CHIUDERE / TO CLOSE / ZUM SCHLIESSEN / POUR FERMER / PARA CERRAR / PARA ENCERRAR

