

# SR9561 - KR9561

PORTAPACCO SPECIFICO - SPECIFIC HOLDER - PORTE-PAQUET SPÉCIFIQUE - SPEZIFISCHER TRÄGER - PORTA-EQUIPAJE ESPECÍFICO - TRANSPORTADOR ESPECÍFICO

N°	Descrizione/Description	Caratteristiche/Features	Codice/Code	Quantità/Quantity
1	Supporto - Support - Support Halterung - Soporte - Suporte	-	GL6468V	1
2	Vite - Screw - Vis - Schraube Tornillo - Parafuso	M8x50 TSP	850TSP	2
3	Vite - Screw - Vis - Schraube Tornillo - Parafuso	M8x35 TSP	835TSP	2
4	Distanziale - Spacer - Entretoise - Distanzstueck Distanciador - Espaçador	Ø22x12 Foro 10,5mm	C22L12F10,5T	2
5	Distanziale - Spacer - Entretoise - Distanzstueck Distanciador - Espaçador	Ø18x30 Foro 10,5mm	C18L30F10,5T	2
6	Dado - Bolt - Erou Mutter - Tuerca - Porca	Dado Autobloccante Flangiato Basso M8 (H.9,5mm)	8DADIFN	4
7	Tappo - Cap - Fiche - Stecker Tapon - Capa	-	13COP	4
8	Particolari Inclusi Nel Kit Viteria Della Piastra Components Included In The Fitting Kit Of The Plate Pièces Inclues Dans Le Kit De Vis De La Platine Die Einzelnen Teile Sind Bei Montagekit Der Platte Enthalten Despieces Incluidos En El Kit De Anclajes De La Parrilla Explodiu Incluído No Kit As Âncoras Da Grelha	-	-	-

IT\_ Nel caso in cui sulle viti originali sia presente del frenafilletti, ripristinarlo durante il montaggio dell'accessorio.

EN\_ If there is threadlocker on the original screws, use threadlocker when mounting the accessory.

DE\_ Falls sich auf den Originalschrauben Schraubensicherungsstoff befand, sollte dieser auch bei der Montage des Zubehörs wieder aufgetragen werden

FR\_ Si du frein filet est présent sur les vis d'origine, l'appliquer également lors du montage de l'accessoire

ES\_ En caso de que el fijador de roscas se encuentre presente en los tornillos originales, colocarlo nuevamente en el montaje del accesorio

PT\_ Se houver trava rosca nos parafusos originais, inserir novamente durante a montagem do acessório

# SR9561 - KR9561

PORTAPACCO SPECIFICO - SPECIFIC HOLDER - PORTE-PAQUET SPÉCIFIQUE - SPEZIFISCHER TRÄGER - PORTA-EQUIPAJE ESPECÍFICO - TRANSPORTADOR ESPECÍFICO

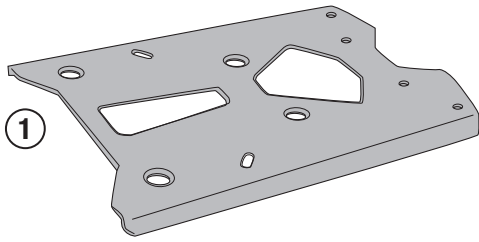

GL6468V

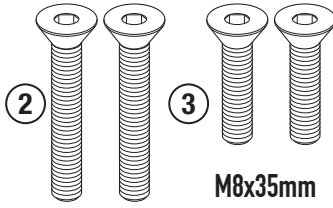

M8x50mm

M8x35mm



Hole  $\varnothing$ 10,5mm/  
External  $\varnothing$ 22mm/  
H.12mm

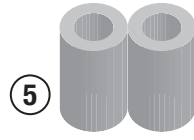

Hole  $\varnothing$ 10,5mm/  
External  $\varnothing$ 18mm/  
H.30mm

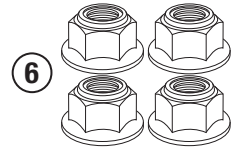

M8

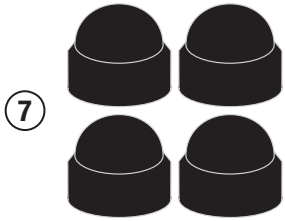

13COP

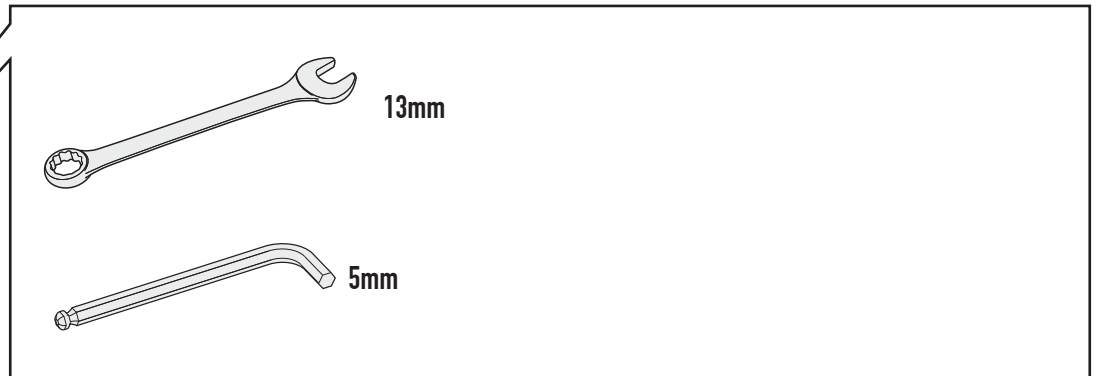
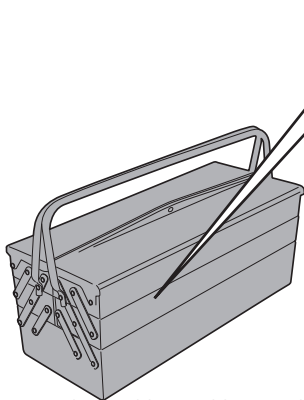

13mm

5mm



CHECK THE SCREW LENGTH HERE

mm

ISTRUZIONI DI MONTAGGIO - MOUNTING INSTRUCTIONS  
INSTRUCTIONS DE MONTAGE - BAUANLEITUNG  
INSTRUCCIONES DE MONTAJE - INSTRUÇÕES DE MONTAGEM

# SR9561 - KR9561

PORTAPACCO SPECIFICO - SPECIFIC HOLDER - PORTE-PAQUET SPÉCIFIQUE - SPEZIFISCHER TRÄGER - PORTA-EQUIPAJE ESPECÍFICO - TRANSPORTADOR ESPECÍFICO

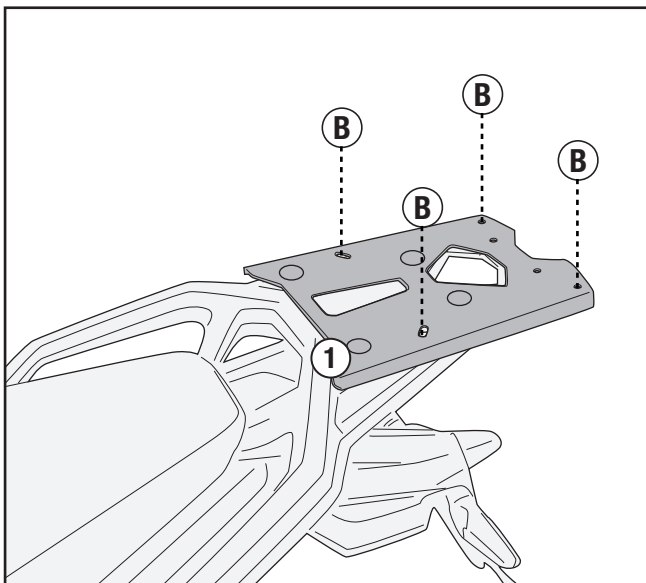
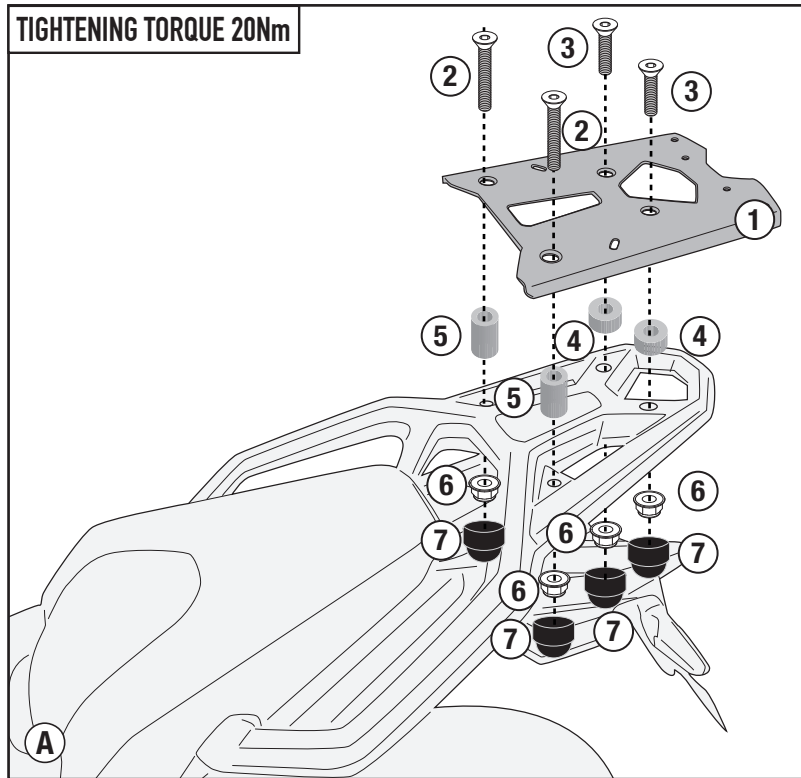

**M5/M7/M10/M5M/  
M6M PLATE**

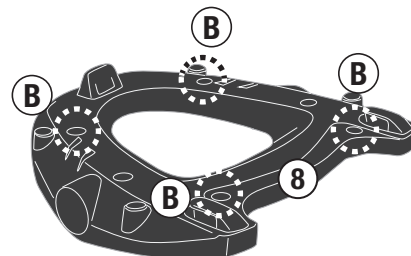

**TIGHTENING TORQUE 7,5Nm**

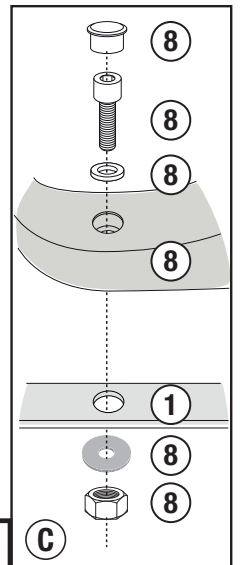

# SR9561 - KR9561

PORTAPACCO SPECIFICO - SPECIFIC HOLDER - PORTE-PAQUET SPÉCIFIQUE - SPEZIFISCHER TRÄGER - PORTA-EQUIPAJE ESPECÍFICO - TRANSPORTADOR ESPECÍFICO

## M8 PLATE

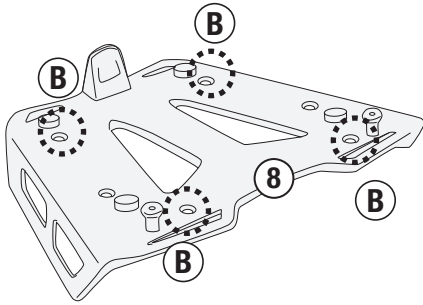

TIGHTENING TORQUE 9,5Nm

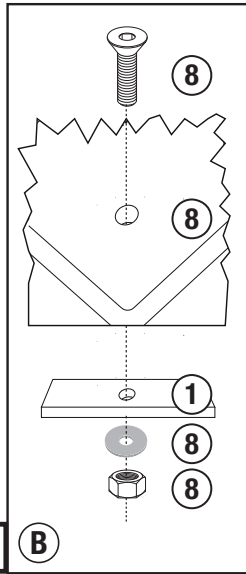

## M9 PLATE

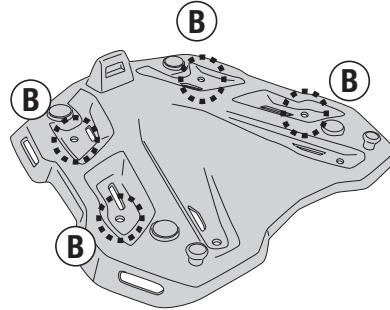

TIGHTENING TORQUE 9,5Nm

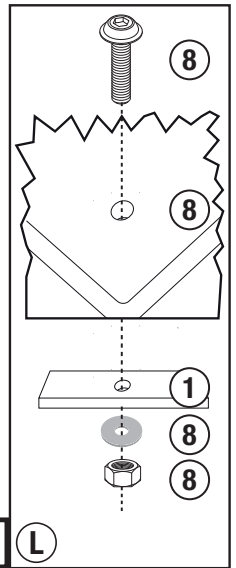

## UNIVERSAL MONOLOCK PLATE (SPARE PART Z113C2)

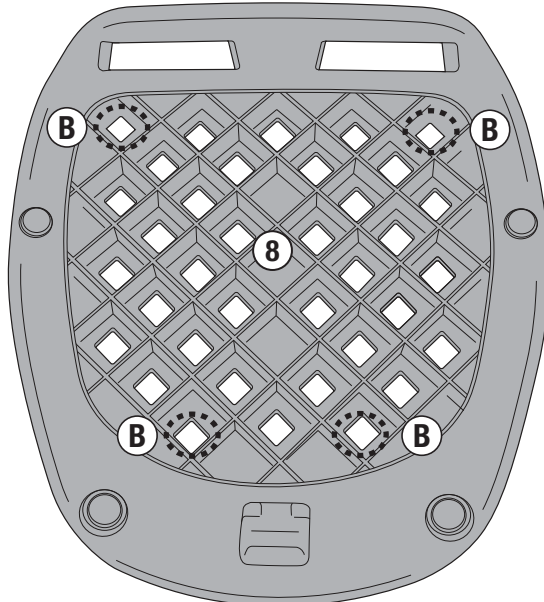

TIGHTENING TORQUE 7,5Nm

