

SR7071 - KR7071

PORTAPACCO SPECIFICO - SPECIFIC HOLDER - PORTE-PAQUET SPÉCIFIQUE - SPEZIFISCHER TRÄGER - PORTA-EQUIPAJE ESPECÍFICO - TRANSPORTADOR ESPECÍFICO

N°	Descrizione/Description	Caratteristiche/Features	Codice/Code	Quantità/Quantity
1	Piastra Centrale - Central plate - Platine centrale Parrilla Central - Platte - Base Central	-	GL5990V	1
2	Vite - Screw - Vis - Schraube Tornillo - Parafuso	M8x140 TCE	8140TCE	1
3	Vite - Screw - Vis - Schraube Tornillo - Parafuso	M5x60 TSP	560TSP	2
4	Vite - Screw - Vis - Schraube Tornillo - Parafuso	M6x45 TSP	645TSP	2
5	Vite - Screw - Vis - Schraube Tornillo - Parafuso	M6x20 TCE	620TCE	2
6	Rondella - Washer - Rondelle - Scheibe Arandela - Arruela	Foro Ø8mm / Esterno Ø20mm Sp.2mm	820RON	1
7	Rondella - Washer - Rondelle - Scheibe Arandela - Arruela	Foro Ø6mm	6RON	2
8	Distanziale - Spacer - Entretoise - Distanzstueck Distanciador - Espaçador	Ø18x48 Foro 10,5mm	C18L48F10,5T	1
9	Distanziale - Spacer - Entretoise - Distanzstueck Distanciador - Espaçador	Ø18x45 Foro 8,5mm	C18L45F8,5T	1
10	Distanziale - Spacer - Entretoise - Distanzstueck Distanciador - Espaçador	Ø16x27 Foro 8,5mm	C16L27F8,5T	2
11	Distanziale - Spacer - Entretoise - Distanzstueck Distanciador - Espaçador	Ø7,5x6,5 Foro 5,2mm	C7,5L6,5F5,2T	2
12	Distanziale - Spacer - Entretoise - Distanzstueck Distanciador - Espaçador	Ø16x18 Foro 8,5mm	C16L18F8,5T	2
13	Distanziale Ribassato - Lowered Spacer - Entretoise Abaissée - Abge- senkter Abstandshalter - espaciador rebajado - espaçador rebaixado	H.9mm	V064	4
14	Distanziale Ribassato - Lowered Spacer - Entretoise Abaissée - Abge- senkter Abstandshalter - espaciador rebajado - espaçador rebaixado	H.11mm	V1107	2
15	Dado - Bolt Ecrou - Mutter- Tuerca - Porca	Dado Autobloccante Flangiato Alto M6 (H9mm)	6DADIAFLN	4
16	Dado - Bolt Ecrou - Mutter- Tuerca - Porca	Dado Autobloccante Flangiato Basso M6 (H7mm)	6DADIABFN	2
17	Coprivite - Screw Cap - Cache Vis - Stopsschraube Tapa Tornillo - Capa do Parafuso	-	6TAP	2
18	Componenti Originali - Original Parts Parties Originales - Original Bauteile Componentes Originales - Componentes Originais	-	-	-
19	Particolari Inclusi Nel Kit Viteria Della Piastra Components Included In The Fitting Kit Of The Plate Pièces Inclues Dans Le Kit De Vis De La Platine Die Einzelnen Teile Sind Bei Montagekit Der Platte Enthalten Despieces Incluidos En El Kit De Anclajes De La Parrilla Explodiu Incluído No Kit As Âncoras Da Grelha	-	-	-

IT_ Nel caso in cui sulle viti originali sia presente del frenafilletti, ripristinarlo durante il montaggio dell'accessorio.

EN_ If there is threadlocker on the original screws, use threadlocker when mounting the accessory.

DE_ Falls sich auf den Originalschrauben Schraubensicherungsstoff befand, sollte dieser auch bei der Montage des Zubehörs wieder aufgetragen werden

FR_ Si du frein filet est présent sur les vis d'origine, l'appliquer également lors du montage de l'accessoire

ES_ En caso de que el fijador de roscas se encuentre presente en los tornillos originales, colocarlo nuevamente en el montaje del accesorio

PT_ Se houver trava rosca nos parafusos originais, inserir novamente durante a montagem do acessório

ISTRUZIONI DI MONTAGGIO - MOUNTING INSTRUCTIONS
INSTRUCTIONS DE MONTAGE - BAUANLEITUNG
INSTRUCCIONES DE MONTAJE - INSTRUÇÕES DE MONTAGEM

SR7071 - KR7071

PORTAPACCO SPECIFICO - SPECIFIC HOLDER - PORTE-PAQUET SPÉCIFIQUE - SPEZIFISCHER TRÄGER - PORTA-EQUIPAJE ESPECÍFICO - TRANSPORTADOR ESPECÍFICO

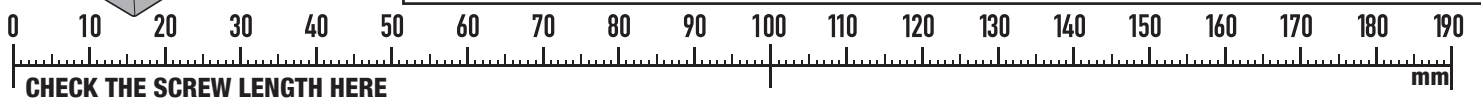
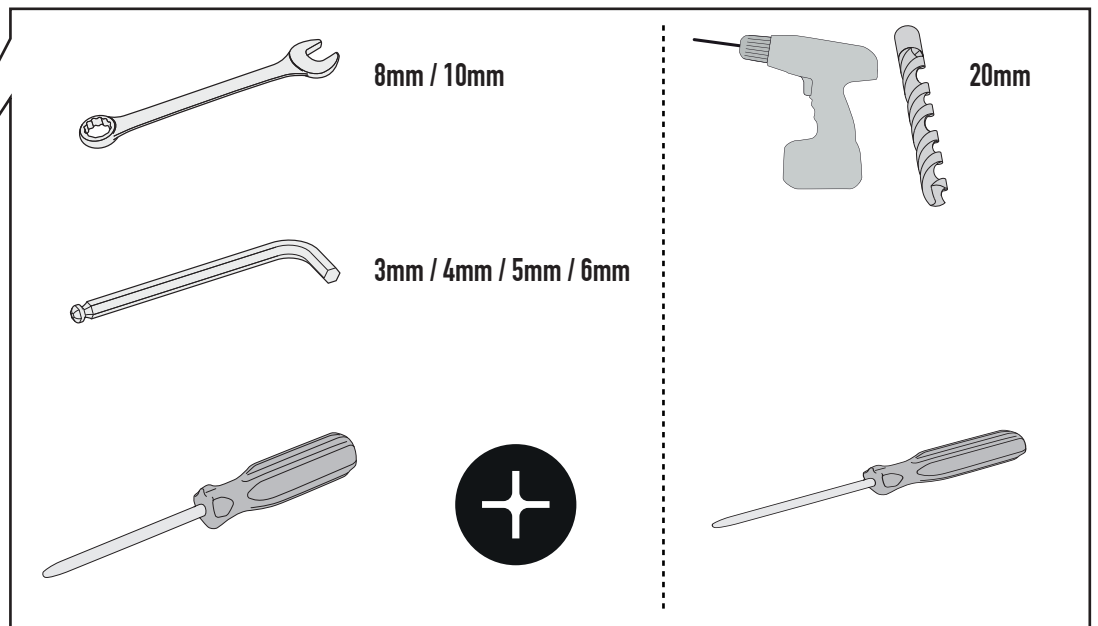
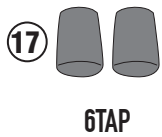
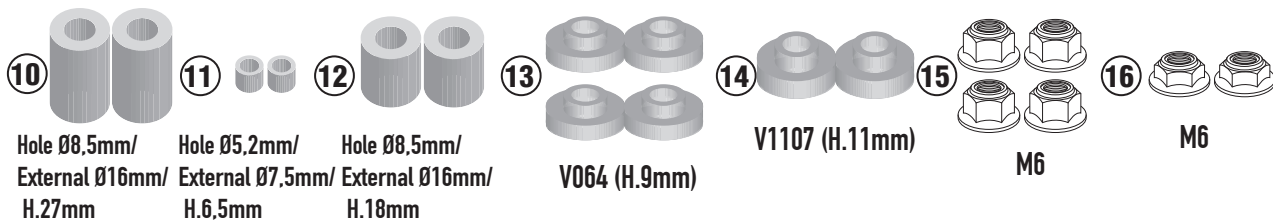
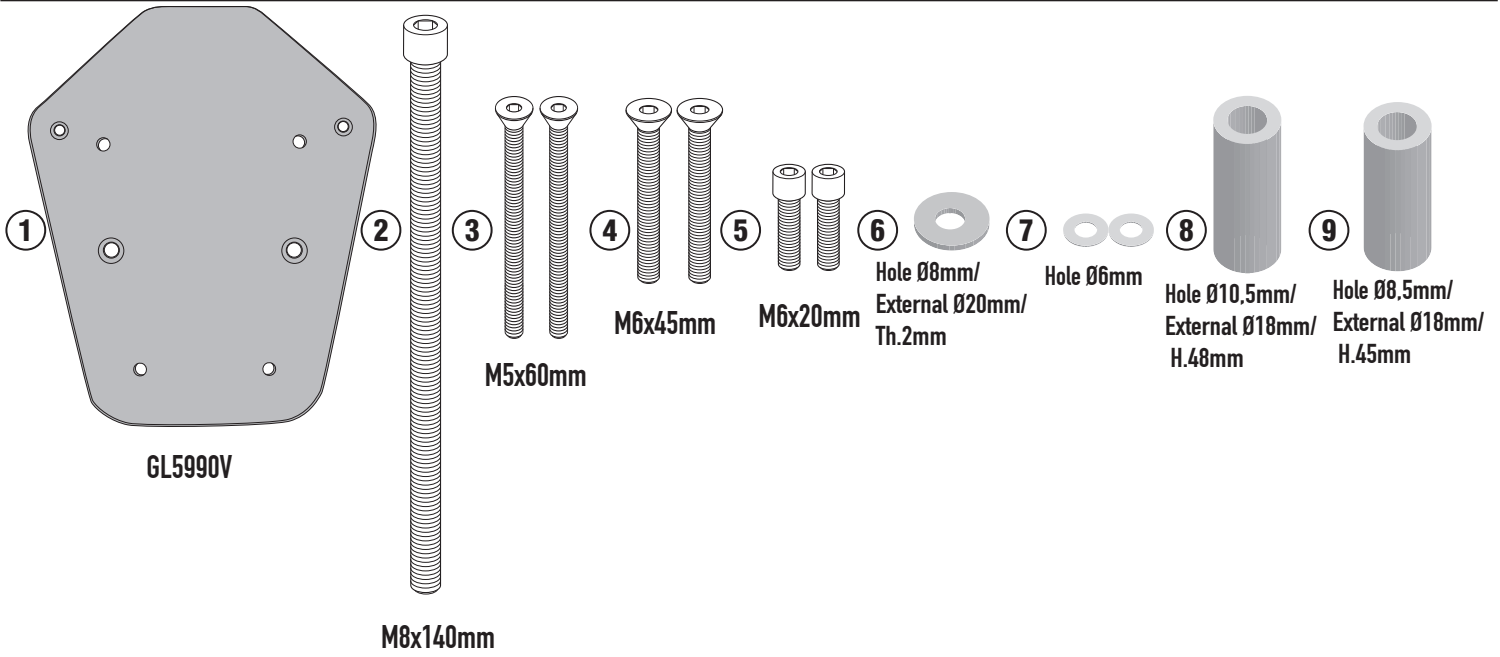

ISTRUZIONI DI MONTAGGIO - MOUNTING INSTRUCTIONS
 INSTRUCCIONES DE MONTAJE - BAUANLEITUNG
 INSTRUCCIONES DE MONTAJE - INSTRUCCIONES DE MONTAJEM

SR7071 - KR7071

PORTAPACCO SPECIFICO - SPECIFIC HOLDER - PORTE-PAQUET SPÉCIFIQUE - SPEZIFISCHER TRÄGER - PORTA-EQUIPAJE ESPECÍFICO - TRANSPORTADOR ESPECÍFICO

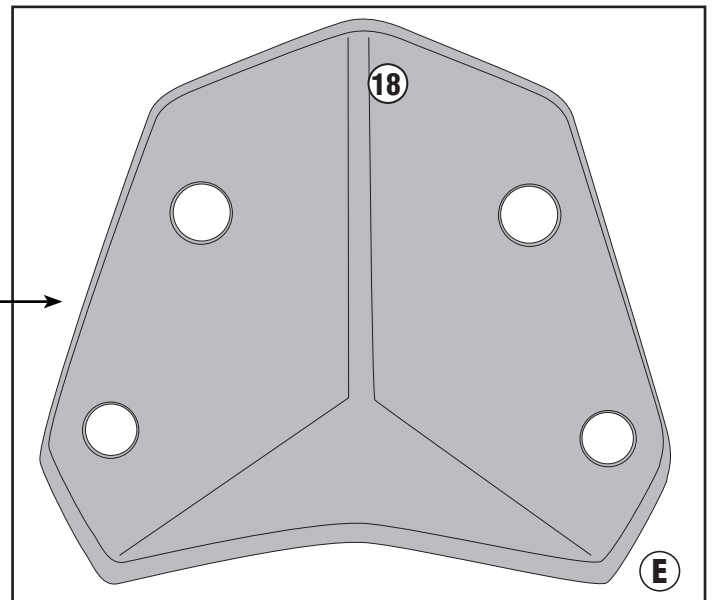
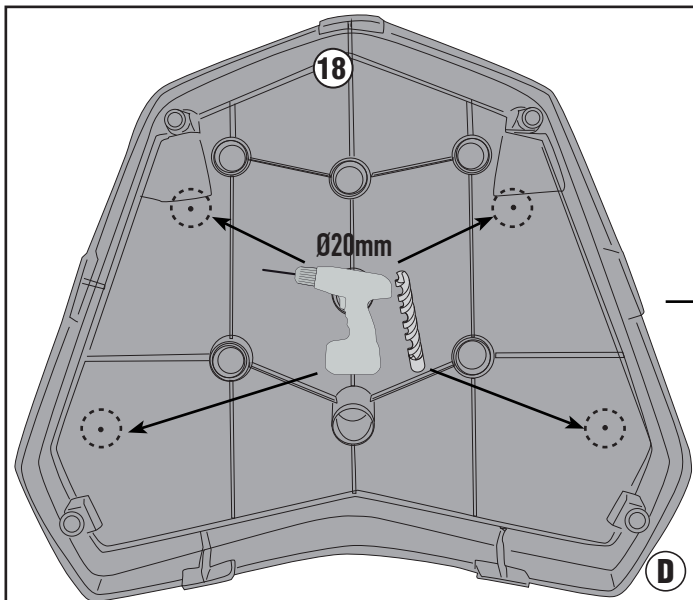
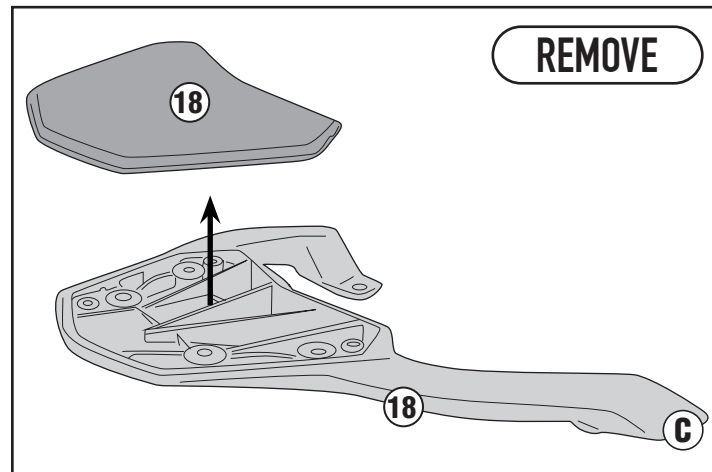
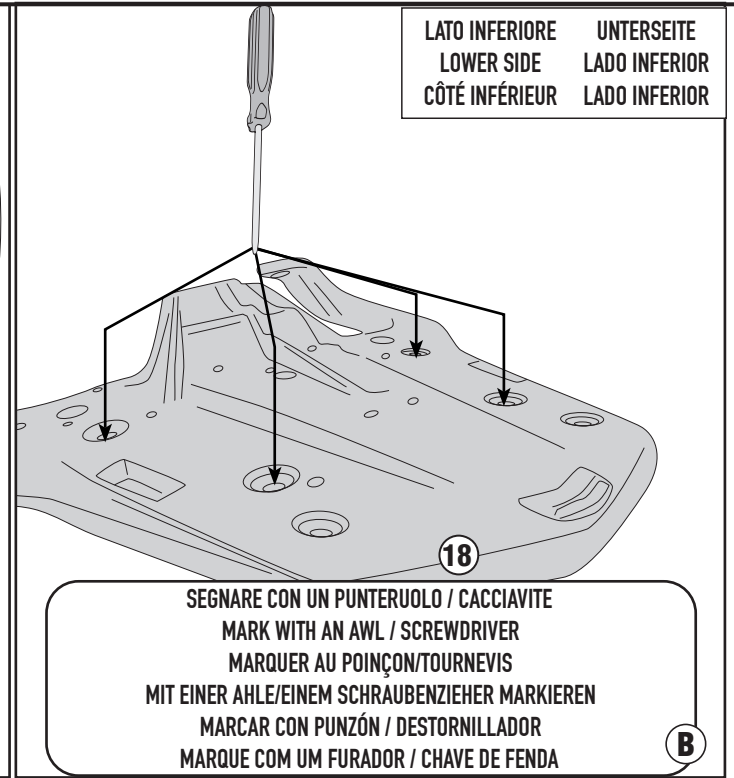
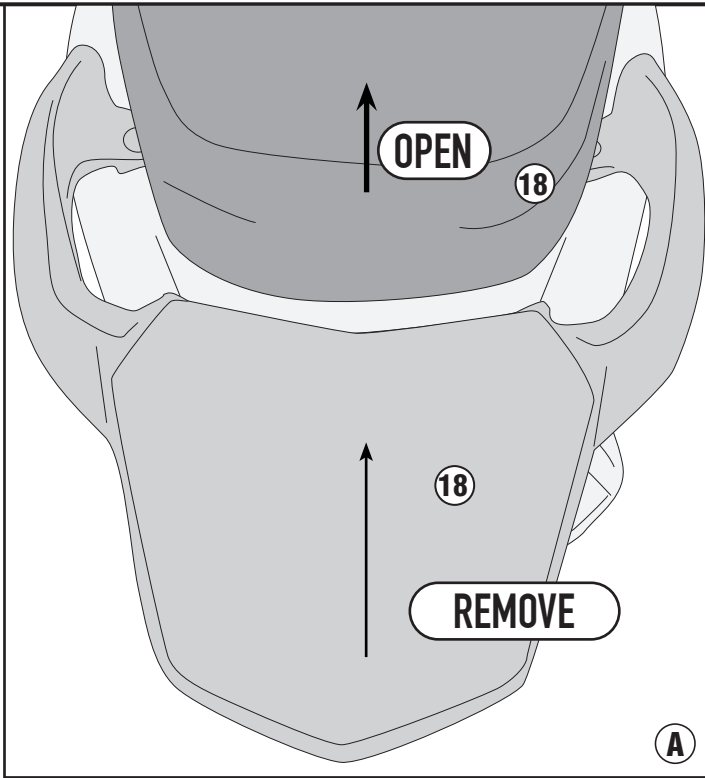

ISTRUZIONI DI MONTAGGIO - MOUNTING INSTRUCTIONS
INSTRUCTIONS DE MONTAGE - BAUANLEITUNG
INSTRUCCIONES DE MONTAJE - INSTRUÇÕES DE MONTAGEM

SR7071 - KR7071

PORTAPACCO SPECIFICO - SPECIFIC HOLDER - PORTE-PAQUET SPÉCIFIQUE - SPEZIFISCHER TRÄGER - PORTA-EQUIPAJE ESPECÍFICO - TRANSPORTADOR ESPECÍFICO

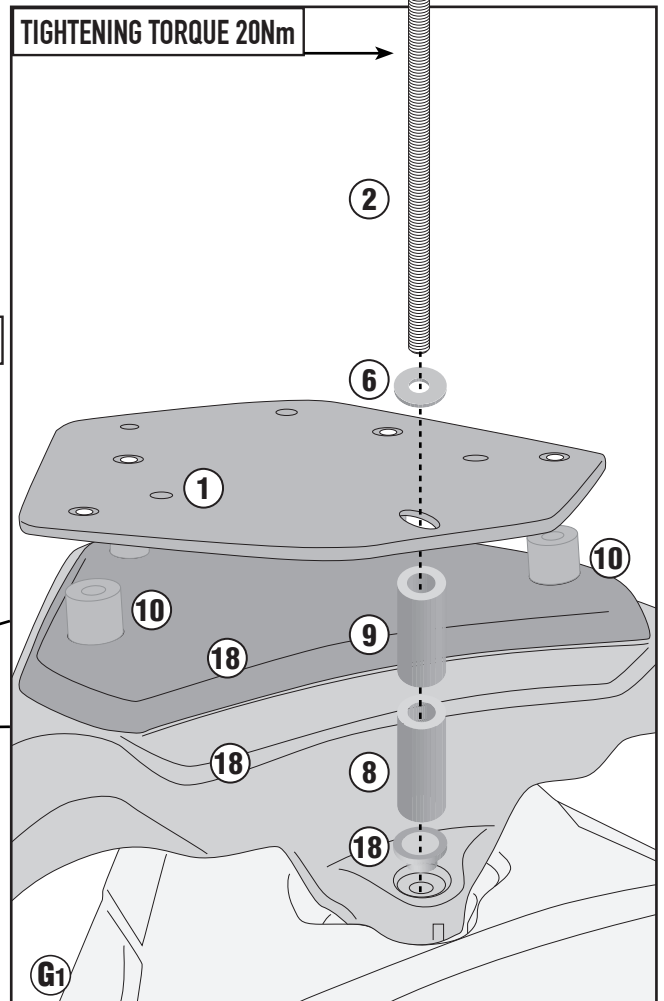
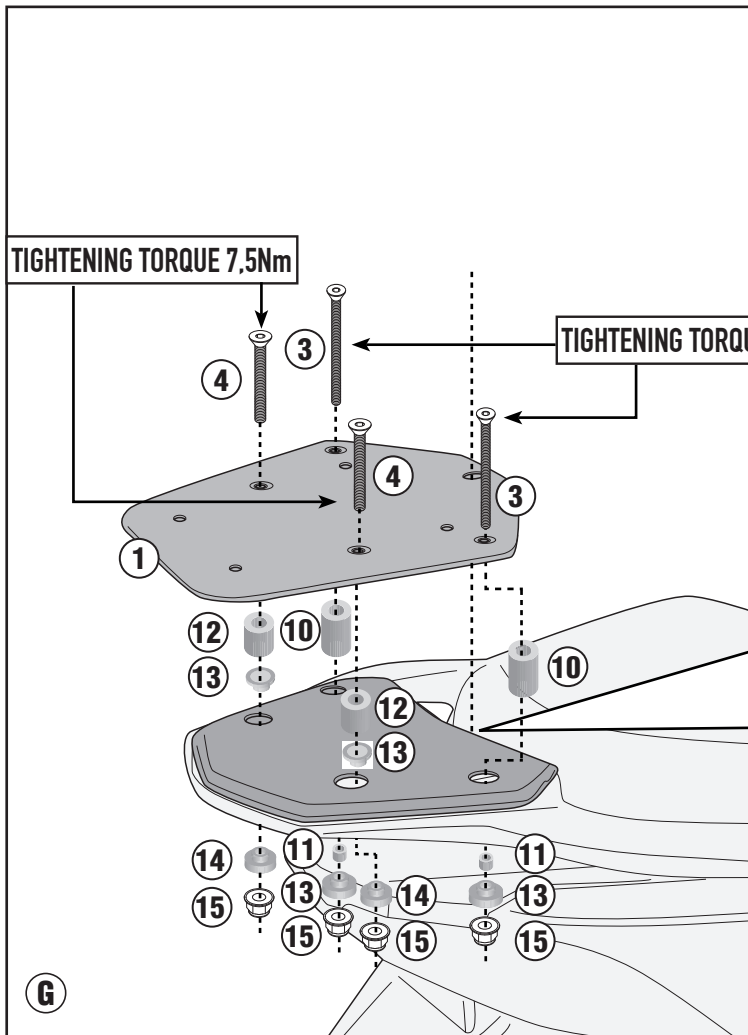
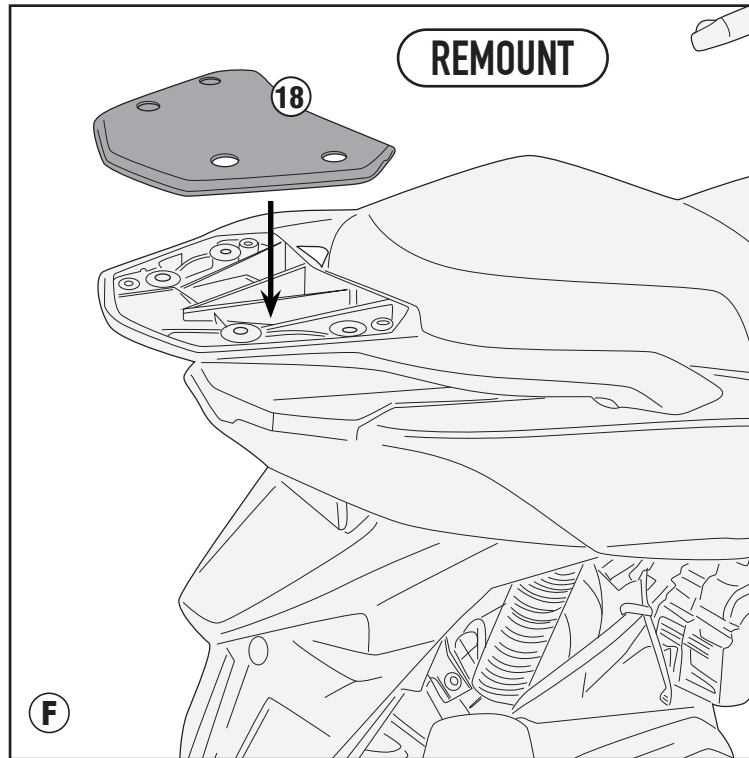

SR7071 - KR7071

PORTAPACCO SPECIFICO - SPECIFIC HOLDER - PORTE-PAQUET SPÉCIFIQUE - SPEZIFISCHER TRÄGER - PORTA-EQUIPAJE ESPECÍFICO - TRANSPORTADOR ESPECÍFICO

