

PL01179N – KL01179N

PORTAVALIGIE LATERALE SPECIFICO – SPECIFIC TUBULAR SIDE-CASE HOLDER – PORTE-VALISES LATÉRAUX SPÉCIFIQUE
SPEZIFISCHES STAHLROHR-SEITENTRAEGER – PORTA MALETAS LATERALES ESPECÍFICO – SUPORTE DE MALAS ESPECÍFICO

HONDA CRF1100L Africa Twin (2020)

N°	Descrizione/Description	Caratteristiche/Features	Codice/Code	Quantità/Quantity
1	Telaio laterale - Side frame - Châssis latéral - Soporte lateral - Seitenrahmen - Suporte lateral	-	PL01179DXV PL01179SXV	2 (Right: Left)
2	Supporto inferiore - Lower support - Support inférieur Soporte inferior - Untere Halterung - Suporte inferior	-	GL4401DXV GL4401SXV	2 (Right: Left)
3	Supporto - Support - Support Halterung - Soporte – Apoio	-	GL4400V	1
4	Vite - Screw Vis - Schraube Tornillo - Parafuso	TCEI M6x60	660TCEI	4
5	Vite - Screw Vis - Schraube Tornillo - Parafuso	TBEI M8x20	820TBEI	4
6	Vite - Screw Vis - Schraube Tornillo - Parafuso	TBEI M8x60	860TBEI	2
7	Vite - Screw Vis - Schraube Tornillo - Parafuso	TBEI M8x65	865TBEI	2
8	Rondella spaccata - Split washer Scheibe - Rondelle fendue Arandela seccionada - Arruela Dentada	Foro Ø8mm	Z1060	4
9	Rondella spaccata - Split washer Scheibe - Rondelle fendue Arandela seccionada - Arruela Dentada	Foro Ø6mm	Z1063	4
10	Rondella - Washer Rondelle - Scheibe Arandela – Arruela	Foro Ø6mm Esterno Ø20mm Sp. 1,5mm	620RON	4
11	Rondella - Washer Rondelle - Scheibe Arandela – Arruela	Foro Ø8,5mm Esterno Ø20mm Sp. 2mm	820RON	12
12	Distanziale - Spacer Entretoise - Distanzstueck Distanciador - Espaçador	Ø14x33,5 Foro 9mm	C14L33,5F9T	4
13	Dado - Bolt - Ecrou Mutter - Tuerca – Porca	Autobloccante Flangiato M8	8DADIFN	4
14	Coprivite - Screw Cap Cache Vis - Stopsschraube Tapa Tornillo - Capa do Parafuso	-	13COP	2
15	Boccola - Mounting bush Entretoise de montage - Cilindro de fijación Montagehülse - Bucha de fixação	-	Z4039	4

PL01179N - KL01179N

PORTAVALIGIE LATERALE SPECIFICO - SPECIFIC TUBULAR SIDE-CASE HOLDER - PORTE-VALISES LATÉRAUX SPÉCIFIQUE
 SPEZIFISCHES STAHLROHR-SEITENTRAEGER - PORTA MALETAS LATERALES ESPECÍFICO - SUPORTE DE MALAS ESPECÍFICO

HONDA CRF1100L Africa Twin (2020)

N°	Descrizione/Description	Caratteristiche/Features	Codice/Code	Quantità/Quantity
16	Componenti Originali - Original Parts Parties Originales - Original Bauteile Componentes Originales - Componentes Originais	-	-	-
17	Particolari Inclusi nel 1179KIT Components Included In The 1179KIT Pièces Incluses Dans 1179KIT Die Einzelnen Teile Sind Bei 1179KIT Despieces Incluidos 1179KIT Componentes incluidos na 1179KIT	-	-	-
18	Particolari Inclusi nel OFMK/OFCAM Components Included In The OFMK/OFCAM Pièces Incluses Dans OFMK/OFCAM Die Einzelnen Teile Sind Bei OFMK/OFCAM Despieces Incluidos OFMK/OFCAM Componentes incluidos na OFMK/OFCAM	-	-	-
19	Particolari Inclusi nel 01RKIT Components Included In The 01RKIT Pièces Incluses Dans 01RKIT Die Einzelnen Teile Sind Bei 01RKIT Despieces Incluidos 01RKIT Componentes incluidos na 01RKIT	-	-	-
20	Particolari Inclusi nel 1179FZ Components Included In The 1179FZ Pièces Incluses Dans 1179FZ Die Einzelnen Teile Sind Bei 1179FZ Despieces Incluidos 1179FZ Componentes incluidos na 1179FZ	-	-	-
21	Supporto - Support - Support Halterung - Soporte - Apoio	-	GN1009V	1



- Da abbinare al kit OFMK per l'utilizzo di valigie Monokey o al kit OFCAM per l'utilizzo di valigie MONOKEY® CAM-SIDE Trekker Outback
- To be combined with OFMK kit for Monokey cases or OFCAM kit for Trekker Outback MONOKEY® CAM-SIDE
- À combiner avec le kit OFMK pour valises MONOKEY® ou le kit OFCAM pour Trekker Outback MONOKEY® CAM-SIDE
- Zu montieren mit kit OFMK für MONOKEY® Koffer oder kit OFCAM für Trekker Outback MONOKEY® CAM-SIDE
- A combinar con el kit OFMK para maletas MONOKEY® o el kit OFCAM para Trekker Outback MONOKEY® CAM-SIDE
- Para ser combinado com o kit OFMK para malas MONOKEY® ou o kit OFCAM para Trekker Outback MONOKEY® CAM-SIDE

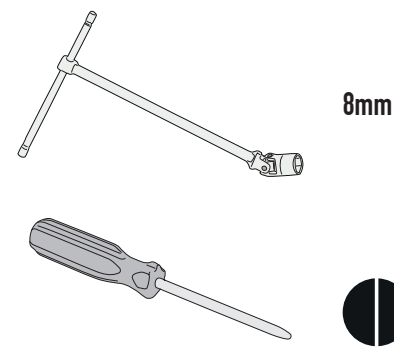
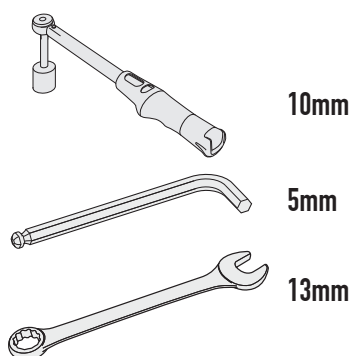
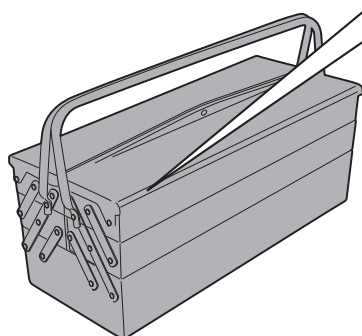

ISTRUZIONI DI MONTAGGIO - MOUNTING INSTRUCTIONS
 INSTRUCTIONS DE MONTAGE - BAUANLEITUNG
 INSTRUCCIONES DE MONTAJE - INSTRUÇÕES DE MONTAGEM

PL01179N - KL01179N

PORTAVALIGIE LATERALE SPECIFICO - SPECIFIC TUBULAR SIDE-CASE HOLDER - PORTE-VALISES LATÉRAUX SPÉCIFIQUE
SPEZIFISCHES STAHLROHR-SEITENTRAEGER - PORTA MALETAS LATERALES ESPECÍFICO - SUPORTE DE MALAS ESPECÍFICO

HONDA CRF1100L Africa Twin (2020)

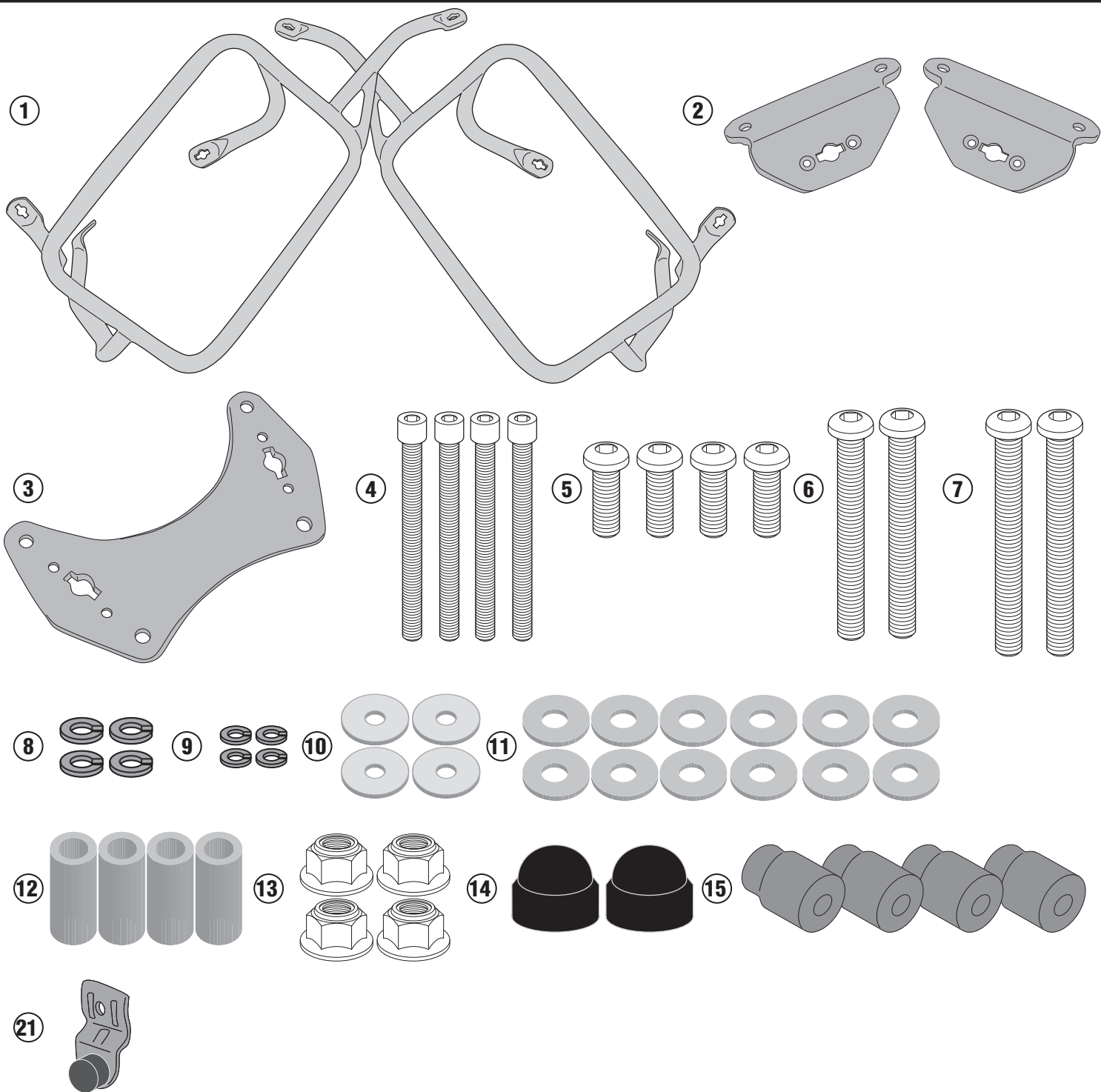

PL01179N - KL01179N

PORTAVALIGIE LATERALE SPECIFICO - SPECIFIC TUBULAR SIDE-CASE HOLDER - PORTE-VALISES LATÉRAUX SPÉCIFIQUE
SPEZIFISCHES STAHLROHR-SEITENTRAEGER - PORTA MALETAS LATERALES ESPECÍFICO - SUPORTE DE MALAS ESPECÍFICO

HONDA CRF1100L Africa Twin (2020)

ONLY FOR THE RIGHT SIDE

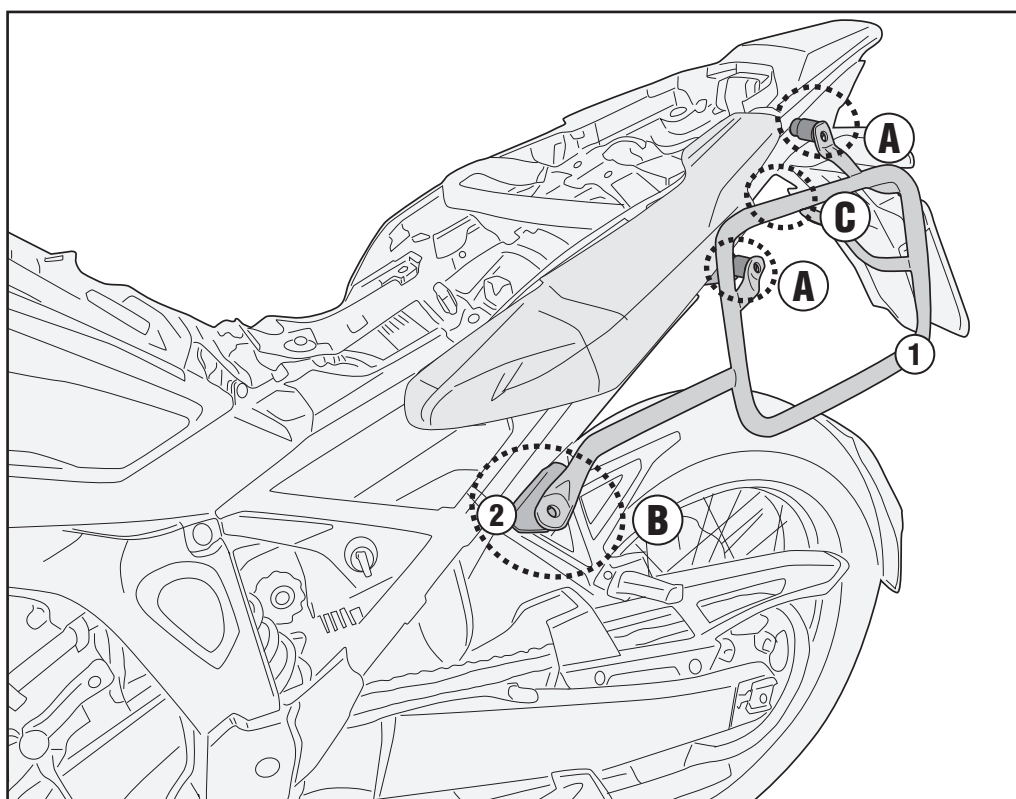
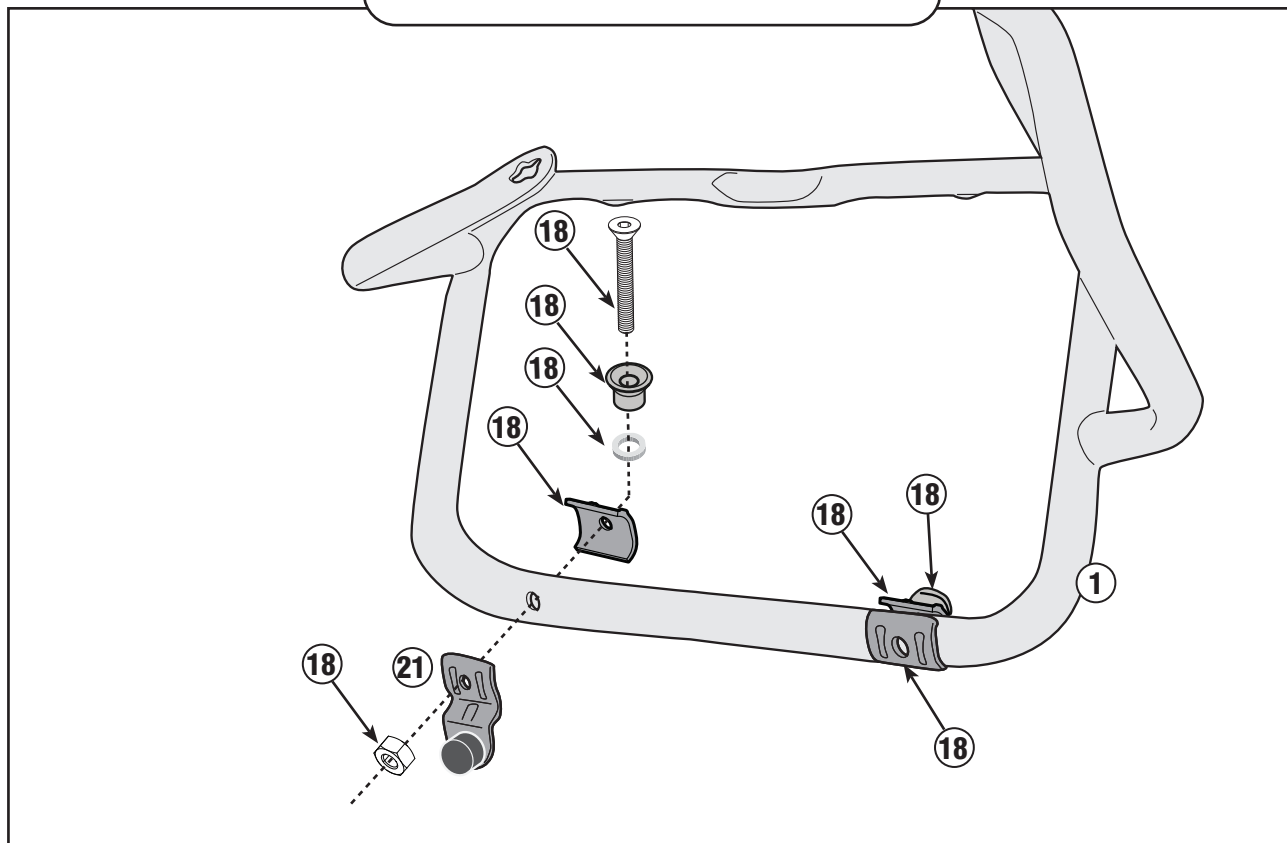

ISTRUZIONI DI MONTAGGIO - MOUNTING INSTRUCTIONS
INSTRUCTIONS DE MONTAGE - BAUANLEITUNG
INSTRUCCIONES DE MONTAJE - INSTRUÇÕES DE MONTAGEM

PL01179N - KL01179N

PORTAVALIGIE LATERALE SPECIFICO - SPECIFIC TUBULAR SIDE-CASE HOLDER - PORTE-VALISES LATÉRAUX SPÉCIFIQUE
SPEZIFISCHES STAHLROHR-SEITENTRAEGER - PORTA MALETAS LATERALES ESPECÍFICO - SUPORTE DE MALAS ESPECÍFICO

HONDA CRF1100L Africa Twin (2020)

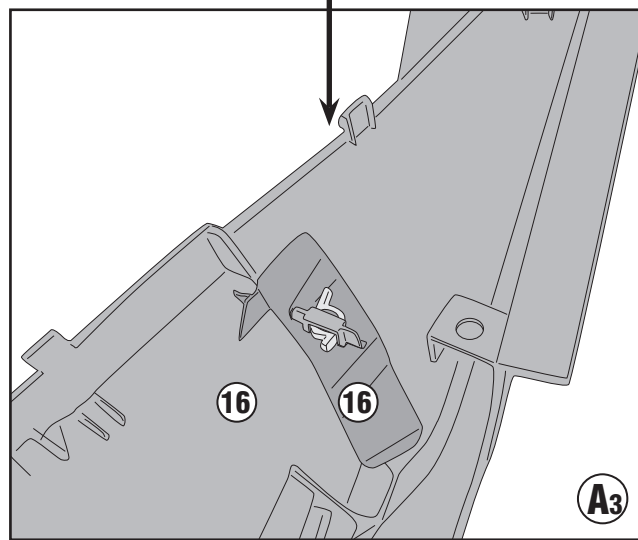
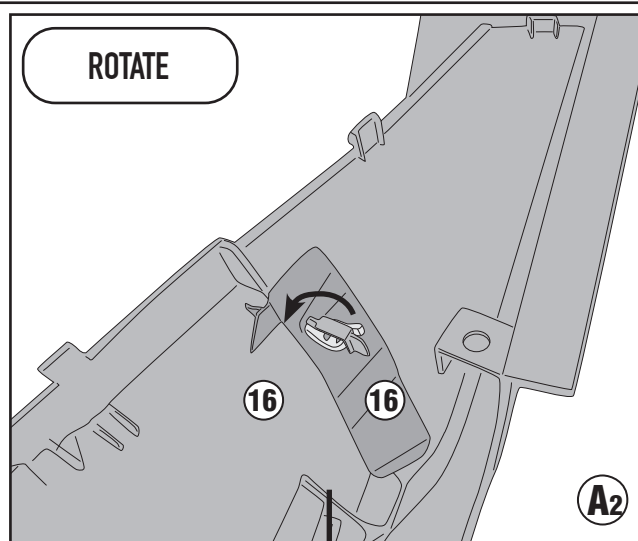
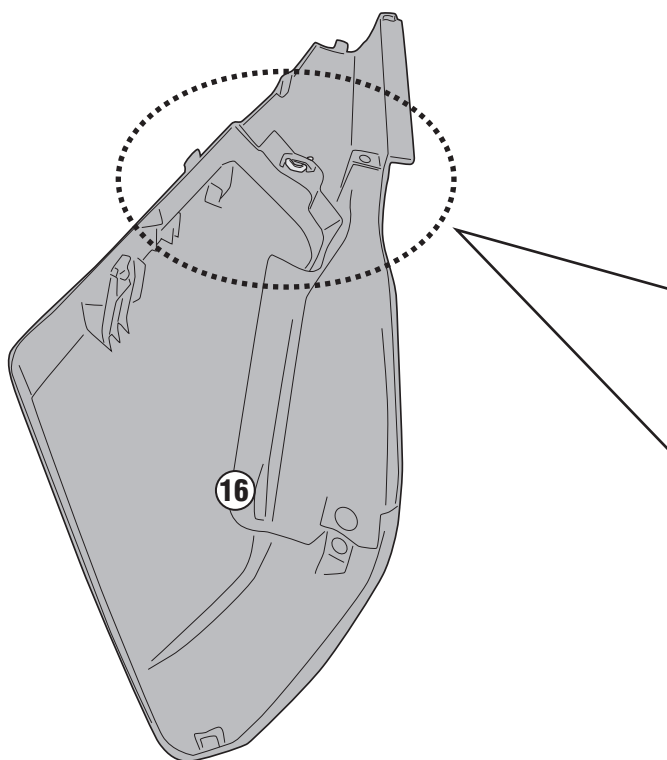
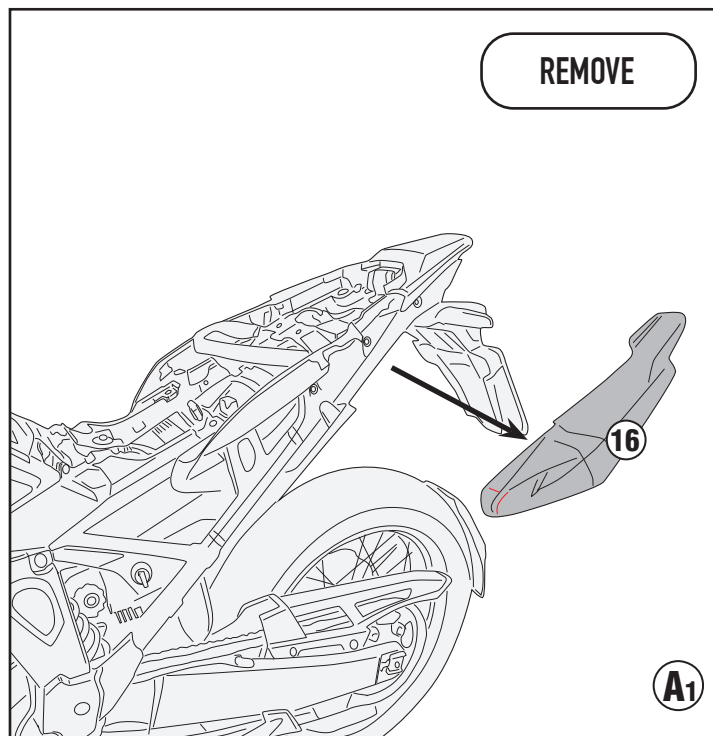
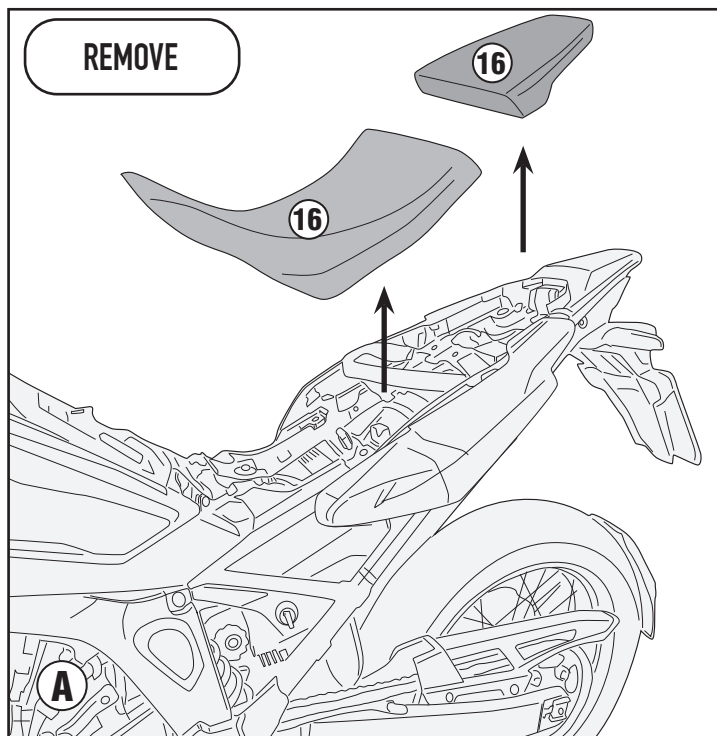

PL01179N - KL01179N

PORTAVALIGIE LATERALE SPECIFICO - SPECIFIC TUBULAR SIDE-CASE HOLDER - PORTE-VALISES LATÉRAUX SPÉCIFIQUE
SPEZIFISCHES STAHLROHR-SEITENTRAEGER - PORTA MALETAS LATERALES ESPECÍFICO - SUPORTE DE MALAS ESPECÍFICO

HONDA CRF1100L Africa Twin (2020)

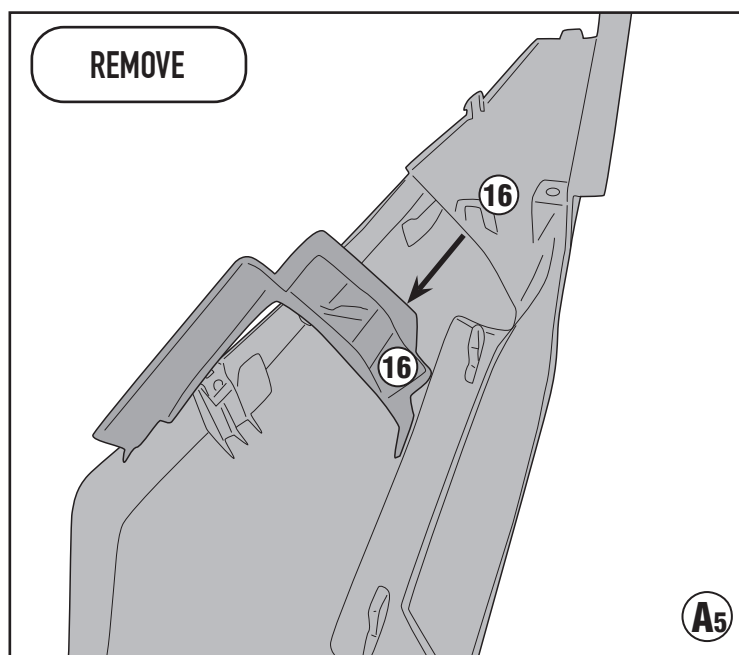
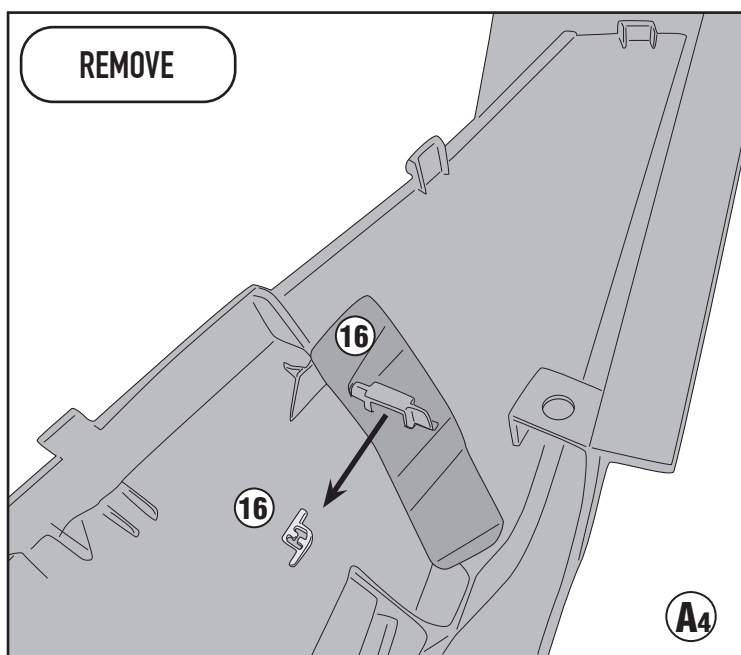

ONLY PL01179

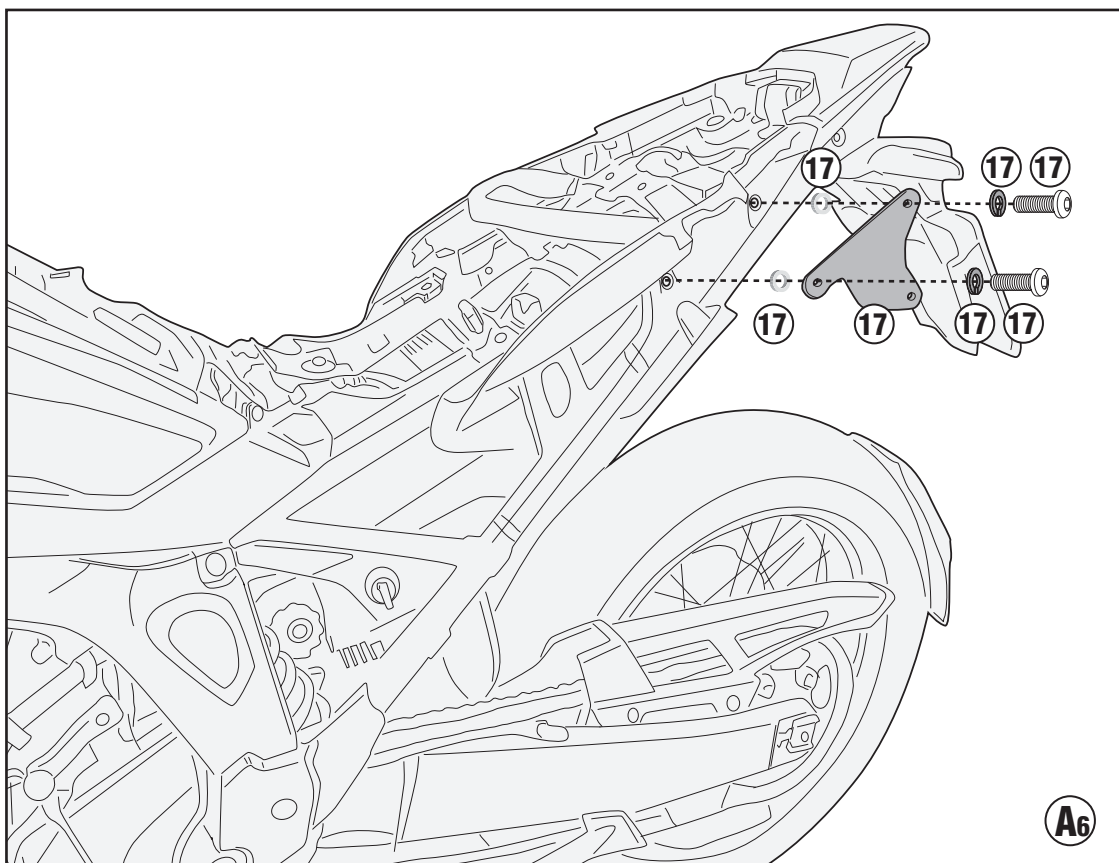

PL01179N - KL01179N

PORTAVALIGIE LATERALE SPECIFICO - SPECIFIC TUBULAR SIDE-CASE HOLDER - PORTE-VALISES LATÉRAUX SPÉCIFIQUE
SPEZIFISCHES STAHLROHR-SEITENTRAEGER - PORTA MALETAS LATERALES ESPECÍFICO - SUPORTE DE MALAS ESPECÍFICO

HONDA CRF1100L Africa Twin (2020)

ONLY PL01179

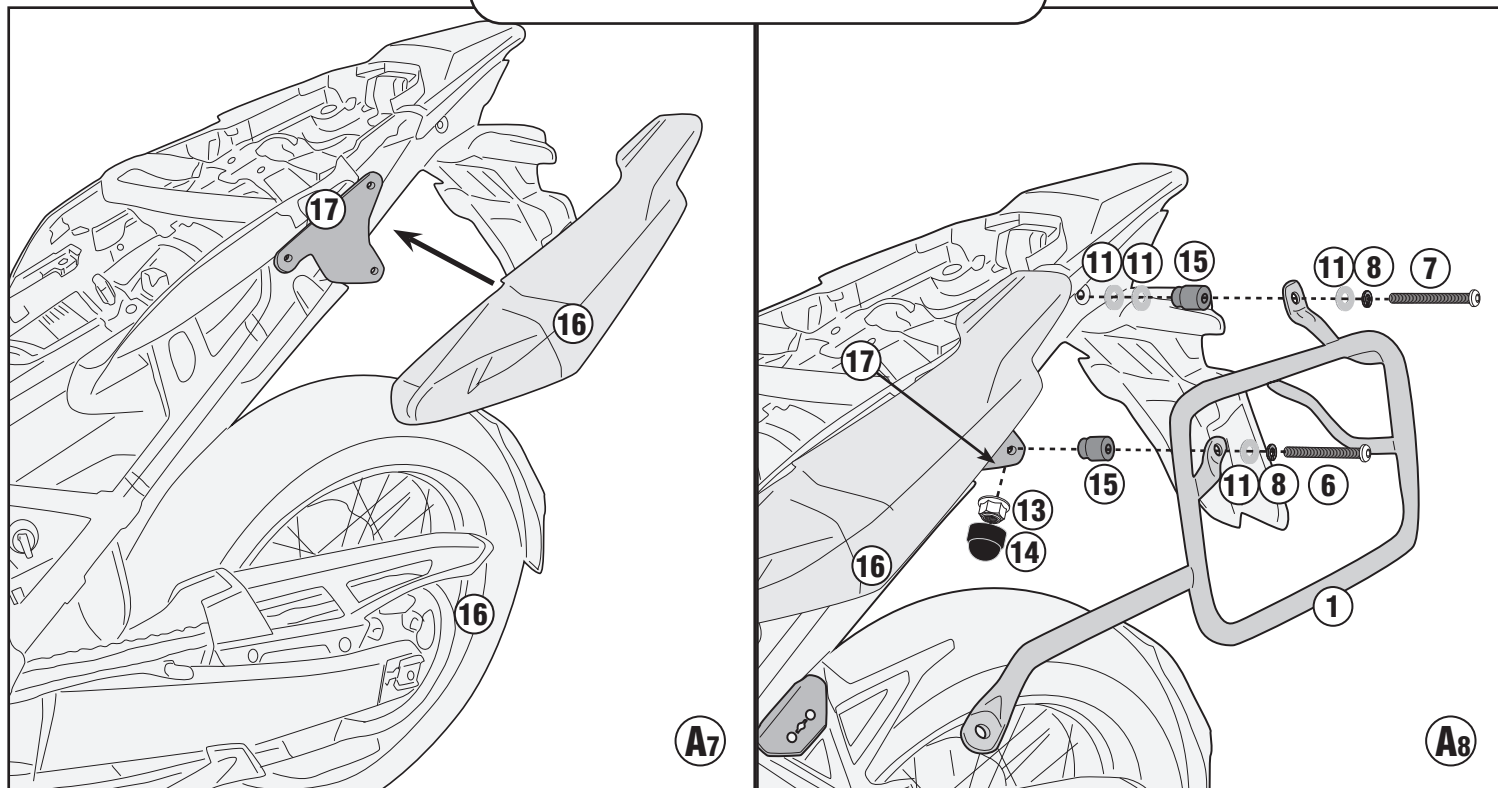

1179FZ + PL01179

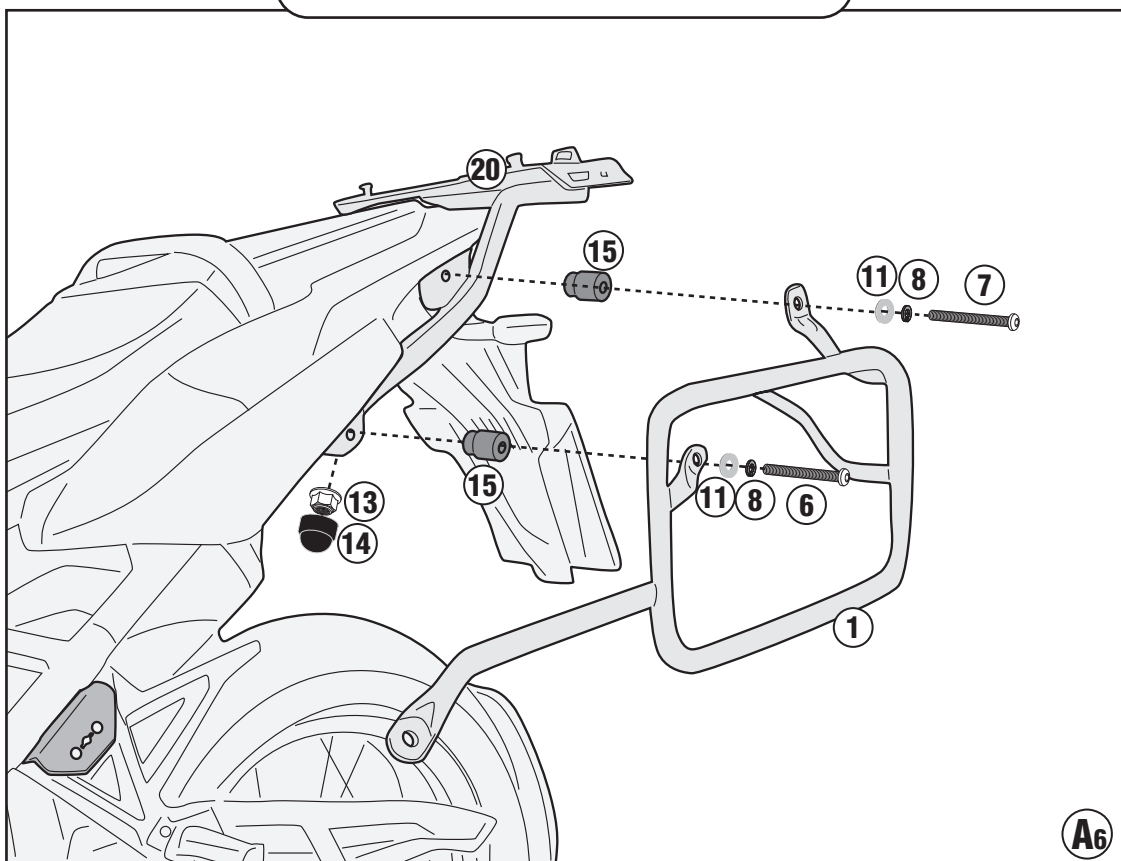

ISTRUZIONI DI MONTAGGIO - MOUNTING INSTRUCTIONS
INSTRUCTIONS DE MONTAGE - BAUANLEITUNG
INSTRUCCIONES DE MONTAJE - INSTRUÇÕES DE MONTAGEM

PL01179N - KL01179N

PORTAVALIGIE LATERALE SPECIFICO - SPECIFIC TUBULAR SIDE-CASE HOLDER - PORTE-VALISES LATÉRAUX SPÉCIFIQUE
SPEZIFISCHES STAHLROHR-SEITENTRAEGER - PORTA MALETAS LATERALES ESPECÍFICO - SUPORTE DE MALAS ESPECÍFICO

HONDA CRF1100L Africa Twin (2020)

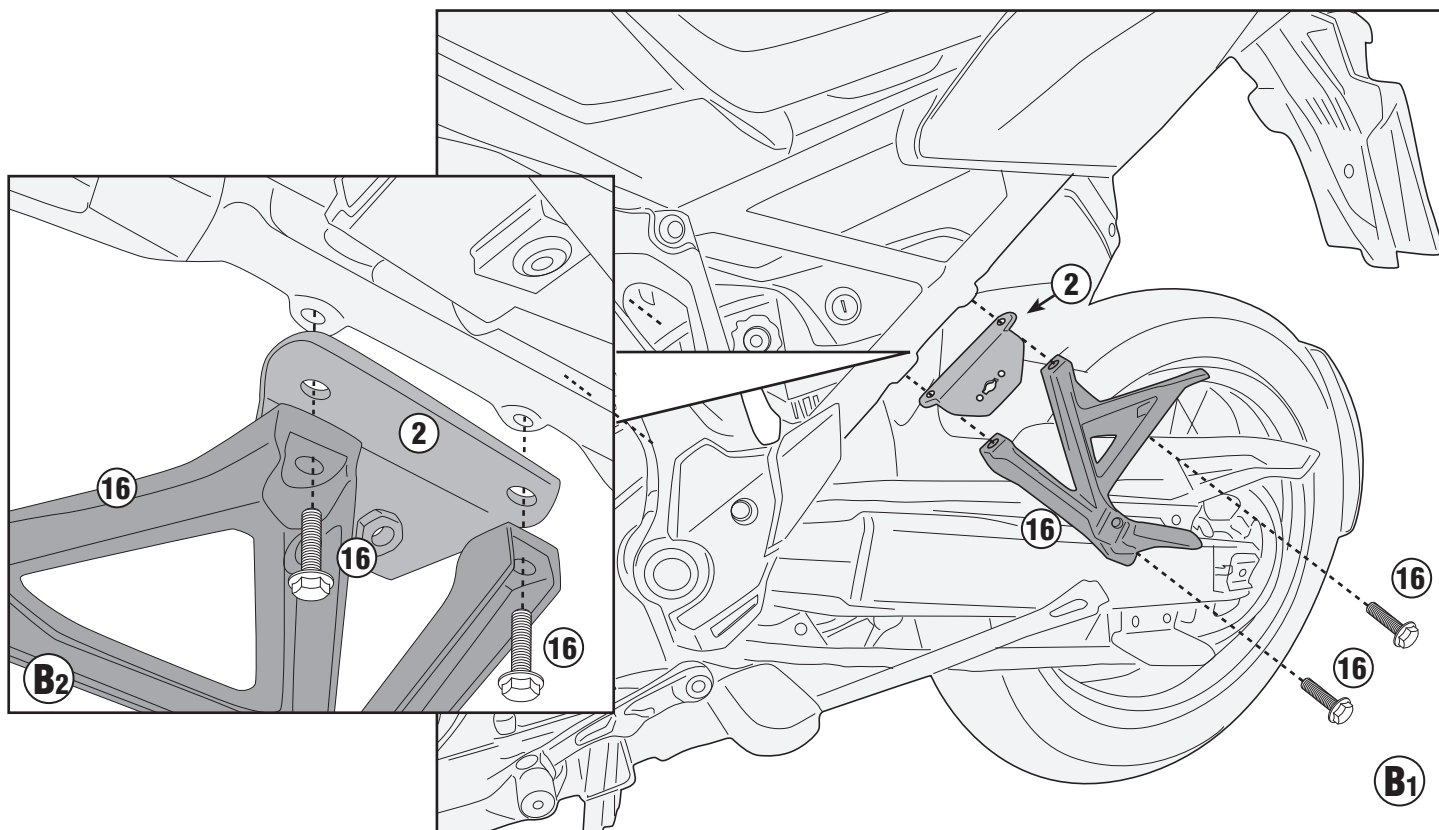
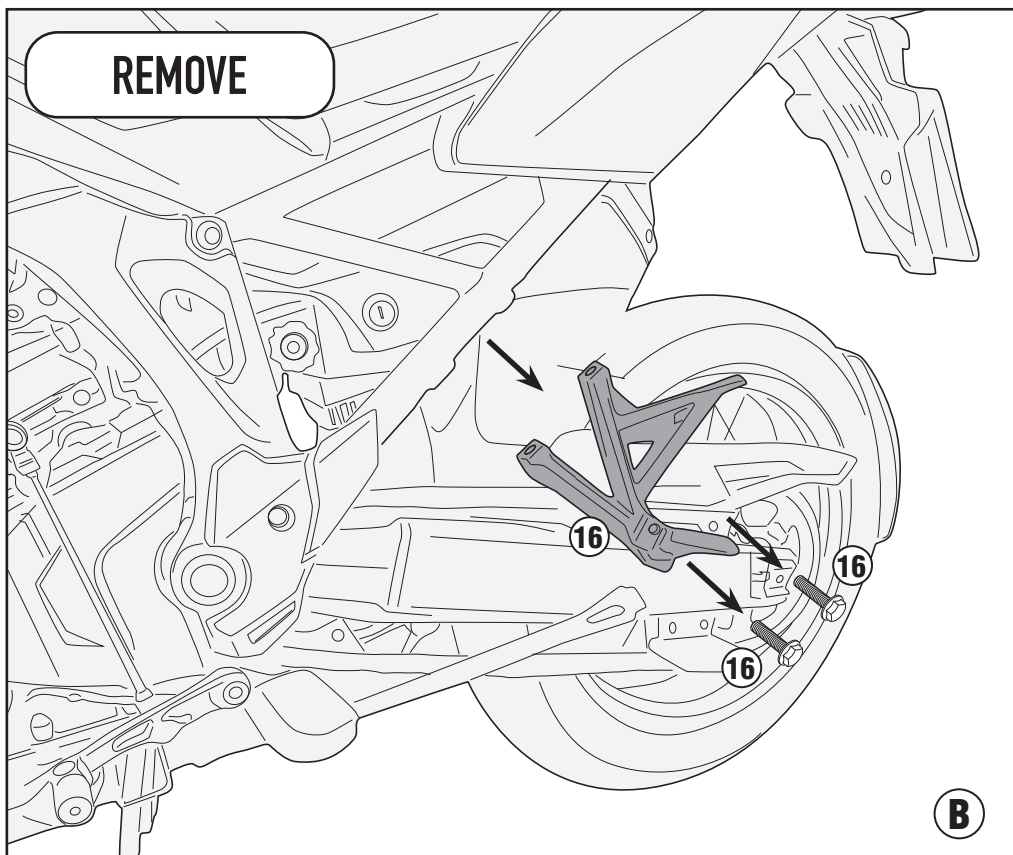

PL01179N - KL01179N

PORTAVALIGIE LATERALE SPECIFICO - SPECIFIC TUBULAR SIDE-CASE HOLDER - PORTE-VALISES LATÉRAUX SPÉCIFIQUE
SPEZIFISCHES STAHLROHR-SEITENTRAEGER - PORTA MALETAS LATERALES ESPECÍFICO - SUPORTE DE MALAS ESPECÍFICO

HONDA CRF1100L Africa Twin (2020)

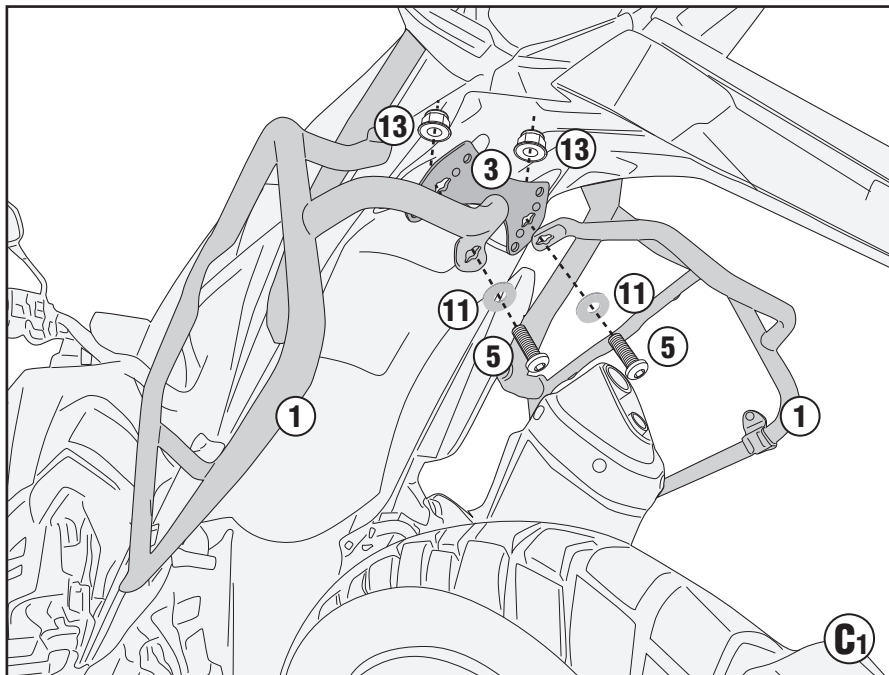
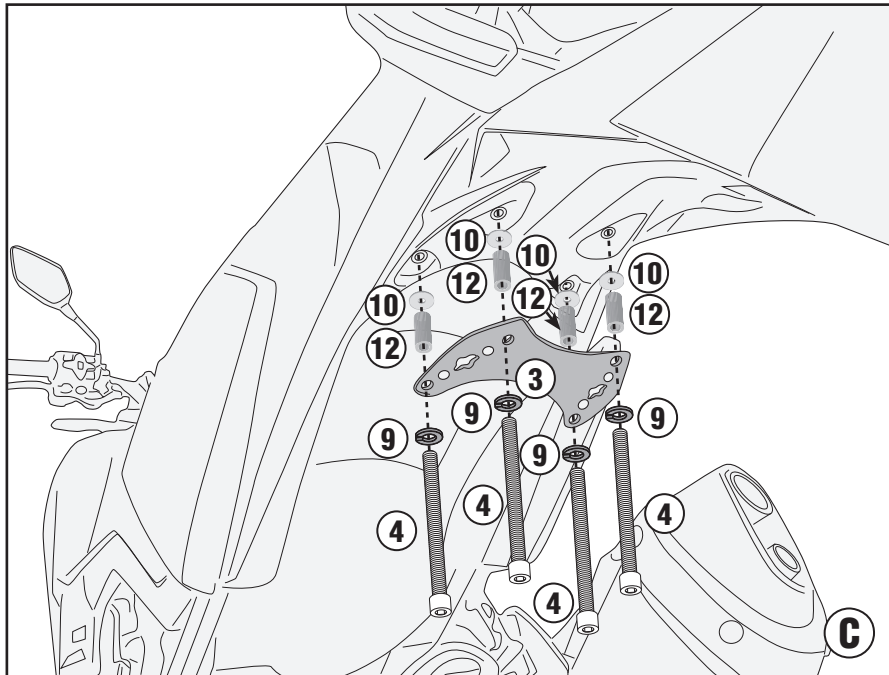

PL01179N - KL01179N

PORTAVALIGIE LATERALE SPECIFICO - SPECIFIC TUBULAR SIDE-CASE HOLDER - PORTE-VALISES LATÉRAUX SPÉCIFIQUE
SPEZIFISCHES STAHLROHR-SEITENTRAEGER - PORTA MALETAS LATERALES ESPECÍFICO - SUPORTE DE MALAS ESPECÍFICO

HONDA CRF1100L Africa Twin (2020)

- TRASFORMAZIONE IN PORTAVALIGIE LATERALI RAPID FITTING, AGGIUNDO IL KIT 01RKIT (DA ACQUISTARE SEPARATAMENTE)
- TRANSFORMATION INTO A RAPID FITTING SIDE-CASE HOLDER, BY ADDING THE 01RKIT KIT (TO BE PURCHASED SEPARATELY)
- VERARBEITUNG ZU EINEM SCHNELL MONTIERBAREN SEITENTRÄGER UNTER HINZUFÜGUNG DES 01RKIT-KITS (SEPARAT ZU ERWERBEN)
 - TRANSFORMABLE EN KIT DE FIXATION LATÉRAL RAPIDE, EN AJOUTANT LE KIT 01RKIT (À ACHETER SÉPARÉMENT)
- SE TRANSFORMA EN UN PORTAMALETAS LATERAL DE AJUSTE RÁPIDO, AÑADIENDO EL KIT 01RKIT (SE COMPRA POR SEPARADO)
- CONVERTE EM UM RACK DE PAINEL LATERAL DE ENCAIXE RÁPIDO, ADICIONANDO O KIT 01RKIT (ADQUIRIDO SEPARADAMENTE)

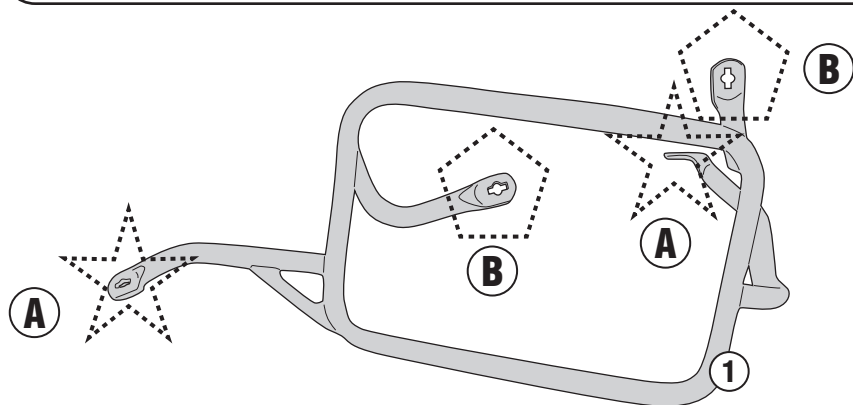

ALWAYS MOUNT THE SCREWS FROM THE OUTSIDE OF THE FRAME

★ TYPE A (See the figure above for the correct type) **CORRECT SIDE**

The diagram illustrates the correct side for mounting the side case holder. It shows a side view of the holder (1) with a screw (19) being inserted from the outside. A warning symbol and the text 'ATTENTION TO THE CORRECT ASSEMBLY' are present. A top-down view shows the holder (1) with a screw (19) being inserted from the outside, with a warning symbol and the text 'ATTENTION TO THE CORRECT ASSEMBLY'. A final view shows the holder (1) with the screw (19) fully inserted.

◐ TYPE B (See the figure above for the correct type) **CORRECT SIDE**

The diagram illustrates the correct side for mounting the side case holder. It shows a side view of the holder (1) with a screw (19) being inserted from the outside. A warning symbol and the text 'ATTENTION TO THE CORRECT ASSEMBLY' are present. A top-down view shows the holder (1) with a screw (19) being inserted from the outside, with a warning symbol and the text 'ATTENTION TO THE CORRECT ASSEMBLY'. A final view shows the holder (1) with the screw (19) fully inserted.

PL01179N - KL01179N

PORTAVALIGIE LATERALE SPECIFICO - SPECIFIC TUBULAR SIDE-CASE HOLDER - PORTE-VALISES LATÉRAUX SPÉCIFIQUE
SPEZIFISCHES STAHLROHR-SEITENTRAEGER - PORTA MALETAS LATERALES ESPECÍFICO - SUPORTE DE MALAS ESPECÍFICO

HONDA CRF1100L Africa Twin (2020)

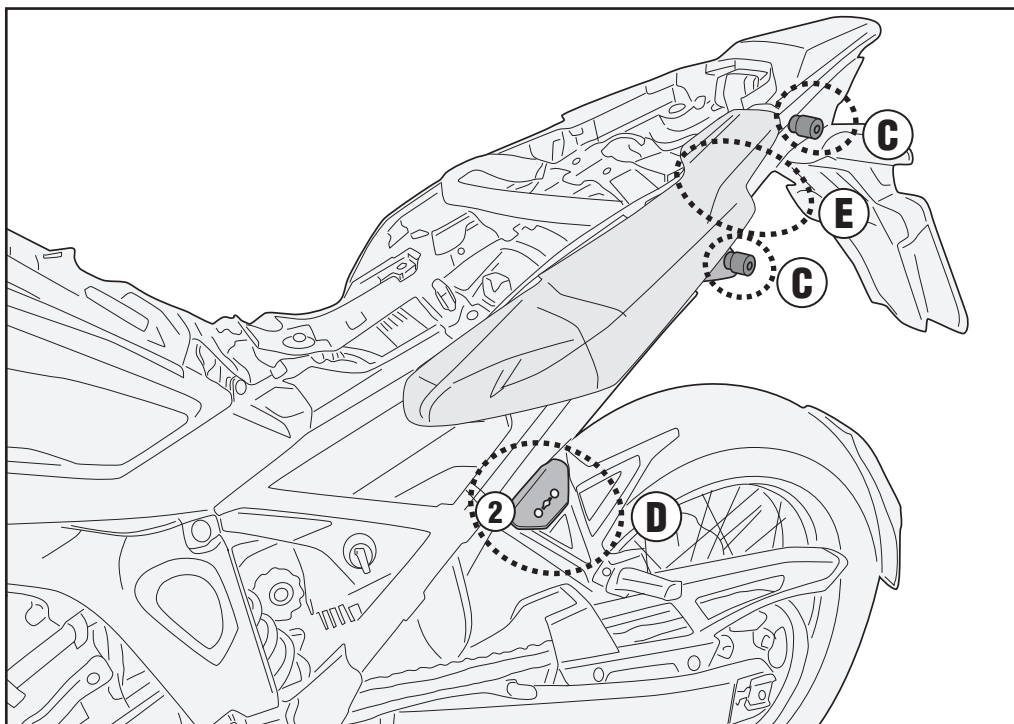

ONLY PL01179

1179FZ + PL01179

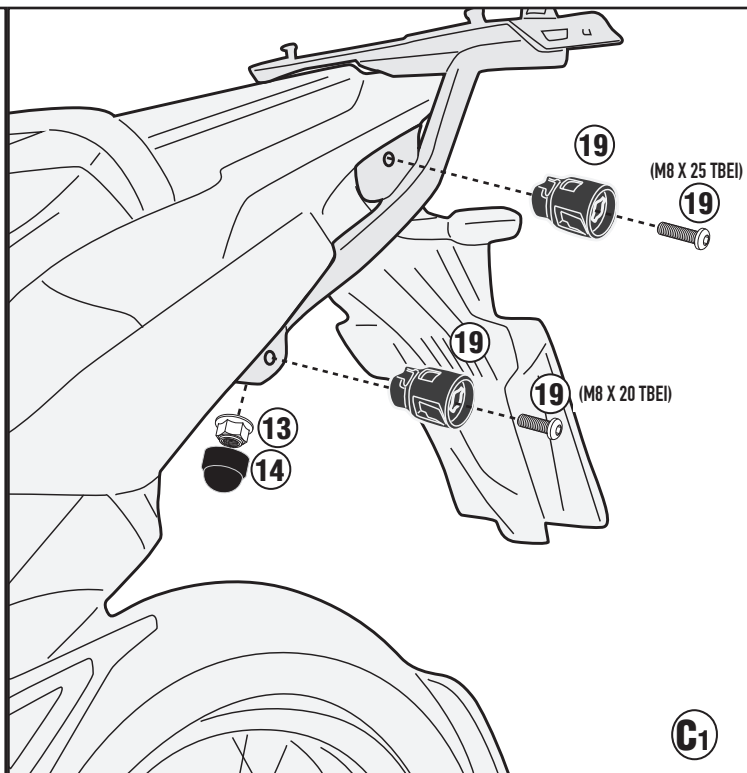
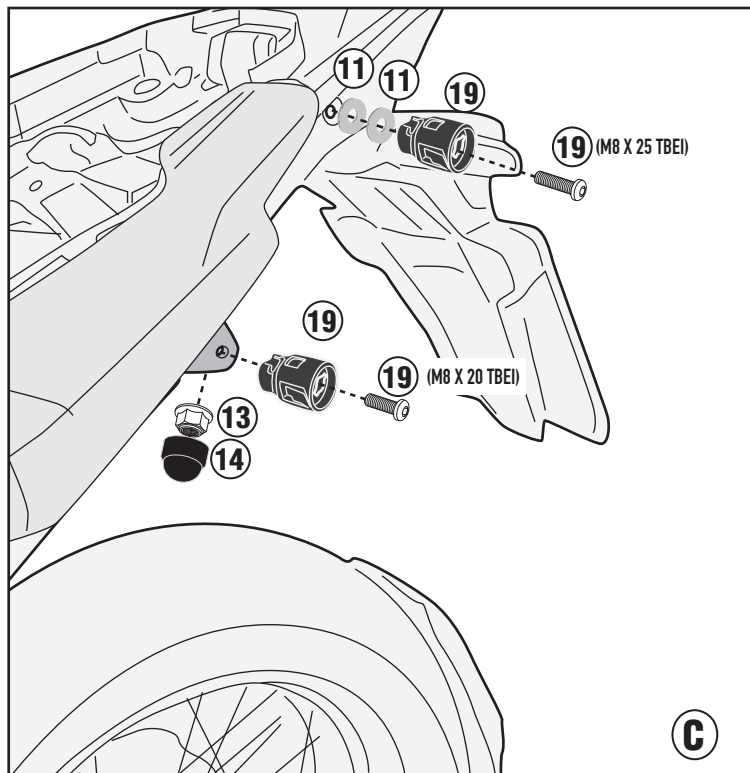

PL01179N - KL01179N

PORTAVALIGIE LATERALE SPECIFICO - SPECIFIC TUBULAR SIDE-CASE HOLDER - PORTE-VALISES LATÉRAUX SPÉCIFIQUE
SPEZIFISCHES STAHLROHR-SEITENTRAEGER - PORTA MALETAS LATERALES ESPECÍFICO - SUPORTE DE MALAS ESPECÍFICO

HONDA CRF1100L Africa Twin (2020)

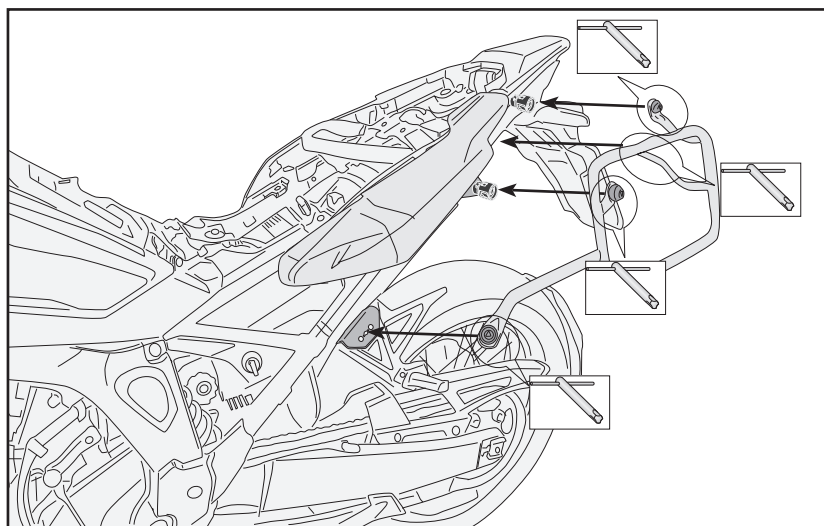
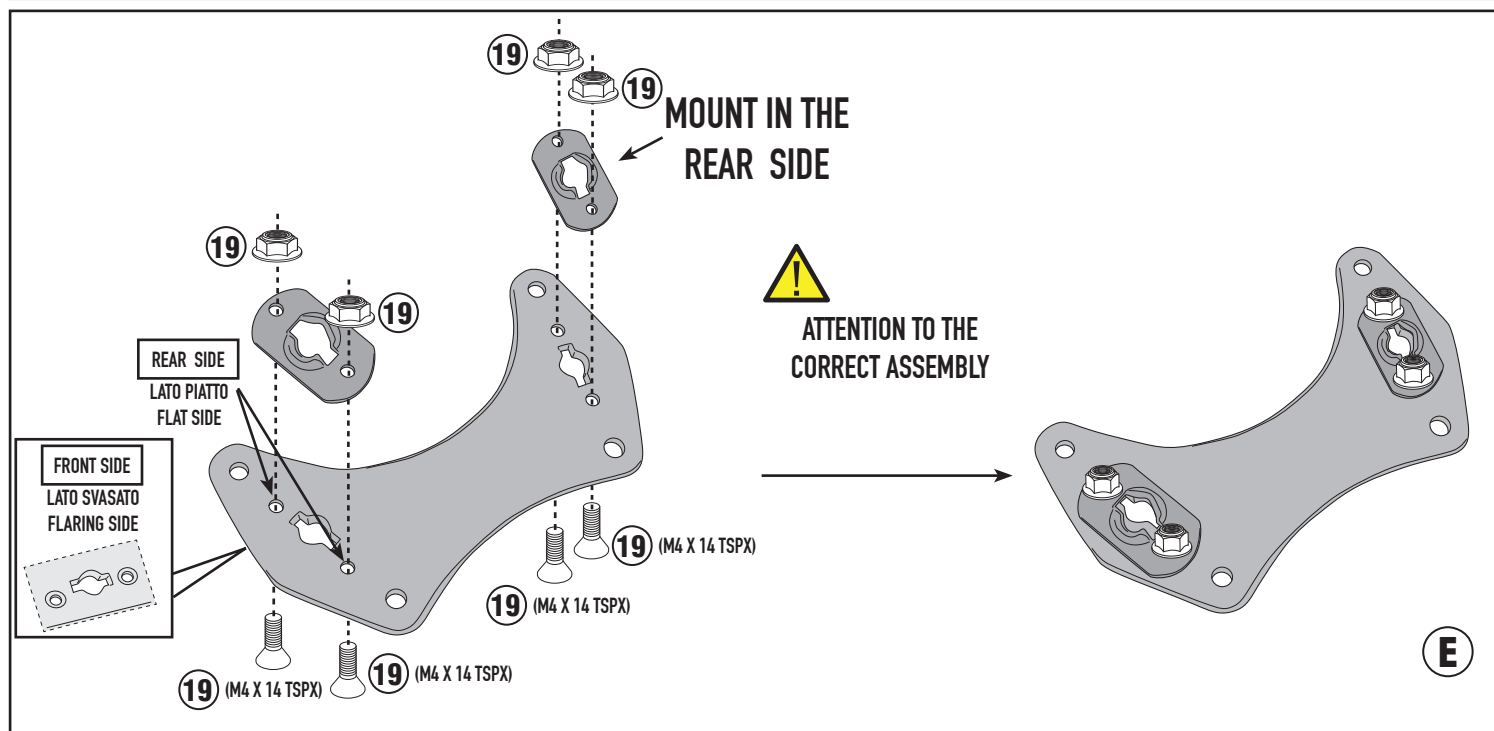
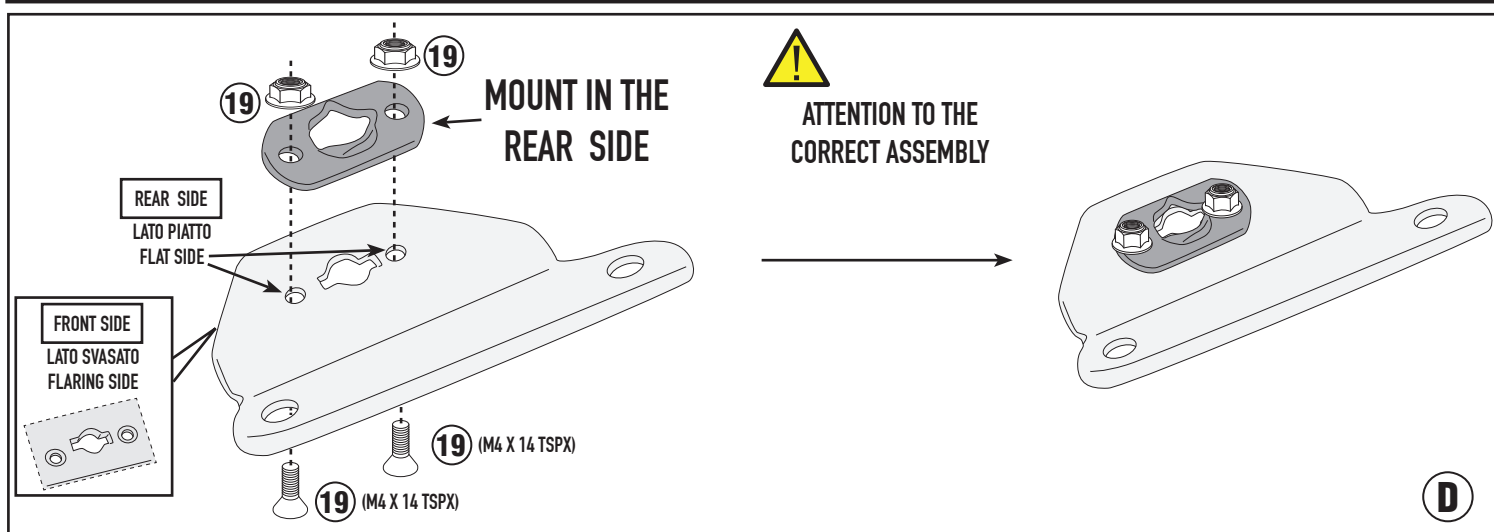

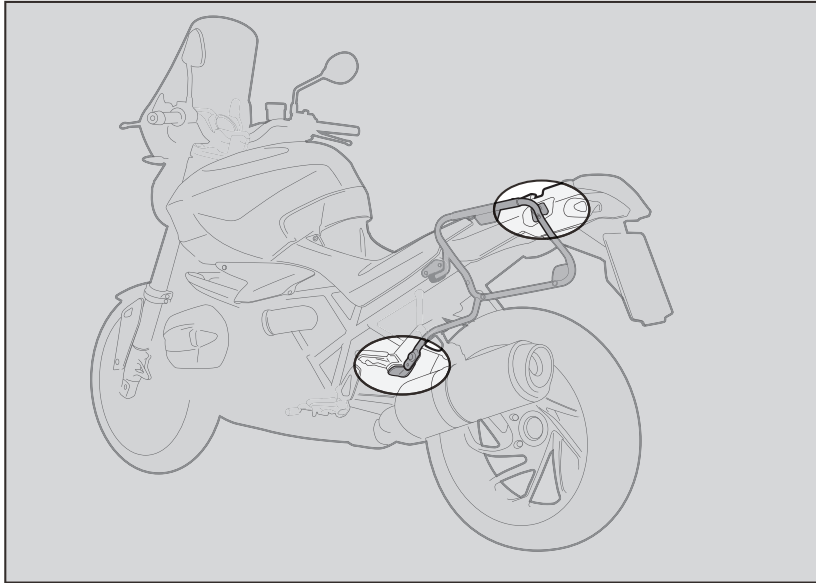

1. INSERIRE L'ATTREZZO NELLA TESTA DELLA VITE SPECIALE;
2. RUOTARE DI 1/4 DI GIRO IN SENSO ORARIO FINO A CHE LA ROTAZIONE NON TERMINA E SI AVVERTE LO SCATTO;
3. PER SMONTARE PROCEDERE IN SENSO INVERSO.

1. INSERT THE SPECIAL KEY INTO THE HEAD OF THE SCREW;
2. TURN THE KEY ¼ TURN CLOCKWISE UNTIL ROTATION STOPS AND THE SIDE CASE HOLDER IS FASTENED SECURELY TO THE FITMENT POINT;
3. IN ORDER TO DISASSEMBLE THE BRACKETRY PERFORM THE OPERATION IN REVERSE.

1. INSERER LA CLE SPECIALE DANS LA TETE DE LA VIS;
2. VISSER D'1/4 DE TOUR DANS LE SENS HORAIRE JUSQU'AU BLOCAGE DE LA VIS POUR MONTER EN TOUTE SECURITE LE SUPPORT A SON POINT DE FIXATION;
3. POUR LE DEMONTAGE, PROCEDER EN SENSE INVERSE.

1. STECKEN SIE DAS WERKZEUG IN DEN KOPF DER SPEZIFISCHEN SCHRAUBE;
2. DREHEN SIE DIE SCHRAUBE 1 / 4 UMDREHUNG IM UHRZEIGERSINN BIS SIE BEMERKEN, DASS DIE SCHRAUBE IM BEFESTIGUNGSPUNKT EINGEKLEMMT IST;
3. FÜR DIE DEMONTAGE FOLGEN SIE DEN HINWEISE UMGEKEHRT.

1. INSERTAR LA LLAVE ESPECIAL EN LA CABEZA DEL TORNILLO
2. DAR ¼ DE VUELTA EN EL SENTIDO HORARIO HASTA QUE LLEGUE AL TOPE Y SE VEA EL TORNILLO;
3. PARA DESMONTARLO PROCEDER EN LA DIRECCIÓN CONTRARIA;

MONTAGGIO - ASSEMBLY - MONTAGE - MONTAGE - MONTAJE

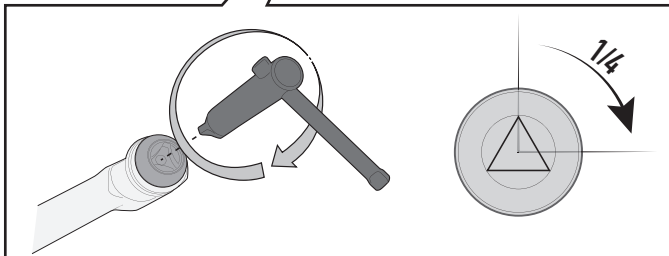
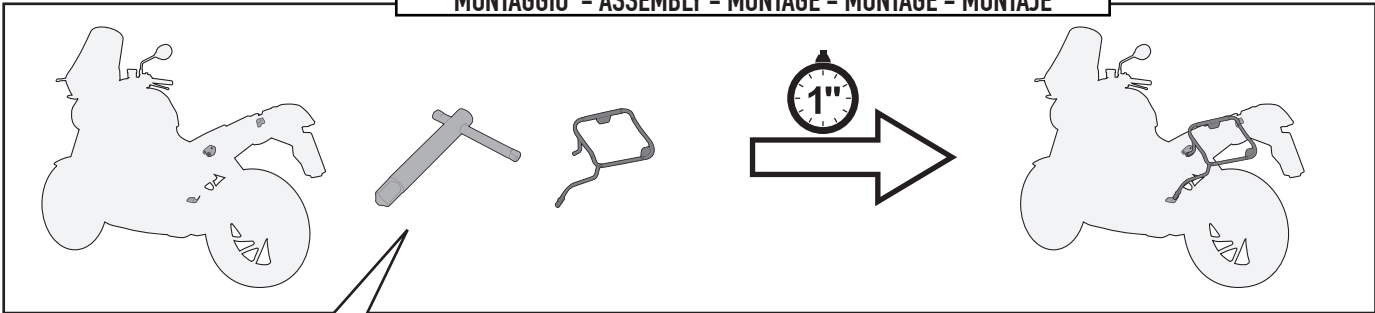

SMONTAGGIO - DISASSEMBLY - DÉMONTAGE - DEMONTAGE - DESMONTAJE

