

PIASTRA SPECIFICA - SPECIFIC PLATE  
PLATINE SPECIFIQUE - SPEZIFISCHE PLATTE - PLETINA ESPECÍFICA

# SUZUKI BURGMAN AN650 2002

ISTRUZIONI DI MONTAGGIO - MOUNTING INSTRUCTIONS  
INSTRUCTIONS DE MONTAGE - BAUANLEITUNG - ISTRUCCIONES DE MONTAJE

1 GL709



PIASTRA  
PLATE  
PLATINE  
PLATTE  
PLETINA

Q.TY n.1

4



VITE TBEI M8x60mm  
SCREW M8x60  
VIS M8x60  
SCHRAUBE M8x60  
TORNILLO M8x60

Q.TY n.2

5

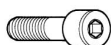

VITE TCEI M6x25  
SCREW M6x25  
VIS M6x25  
SCHRAUBE M6x25  
TORNILLO M6x25

Q.TY n.4

6



RONDELLA Ø8x14  
WASHER Ø8x14  
RONDELLE Ø8x14  
SCHEIBE Ø8x14  
ARANDELA Ø8x14

Q.TY n.3

7



DISTANZIALE Ø16x50  
foro 8,5 NERO  
SPACER  
ENTRETOISE  
DISTRANZSTUECK  
DISTANCIADOR

Q.TY n.1

8



DISTANZIALE Ø16x40  
foro 8,5 NERO  
SPACER  
ENTRETOISE  
DISTRANZSTUECK  
DISTANCIADOR

Q.TY n.2

2



PIASTRA  
PLATE  
PLATINE  
PLATTE  
PLETINA

Q.TY n.1

3



VITE TBEI M8x70mm  
SCREW M8x70  
VIS M8x70  
SCHRAUBE M8x70  
TORNILLO M8x70

Q.TY n.1

9



DADO A.B. M6  
BOLT M6  
ECROU M6  
MUTTER M6  
TUERCA M6

Q.TY n.4

10



RONDELLA Ø6  
WASHER Ø6  
RONDELLE Ø6  
SCHEIBE Ø6  
ARANDELA Ø6

Q.TY n.8

11



COPRIFORO  
BOLT CAP  
CACHE TROU  
LOCKKAPPE  
TAPA AGUJERO

Q.TY n.6

12



TAPPO ANTIFURTO  
ANTI-THEFT CAP  
BOUCHON ANTIVOL  
ANTI-DIEBSTAHL KAPPE  
TAPON ANTIRROBO

Q.TY n.1

13



GOMMINO  
RUBBER  
CAOUTCHOUC  
GUMMI  
GOMA

Q.TY n.4

14



RONDELLA MOUSSE  
Ø32x3mm, foro Ø15  
WASHER  
RONDELLE  
SCHEIBE  
ARANDELA

Q.TY n.3

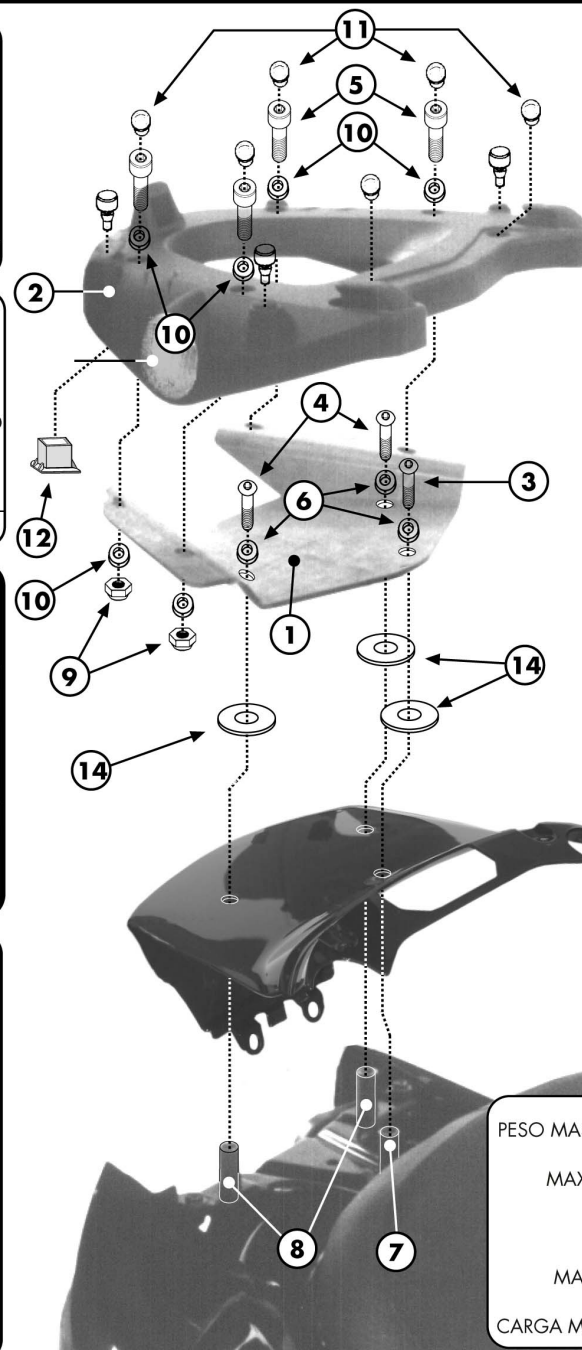

A

TOGLIERE  
TAKE OFF  
ENLEVER  
ENTFERNEN  
QUITAR



B

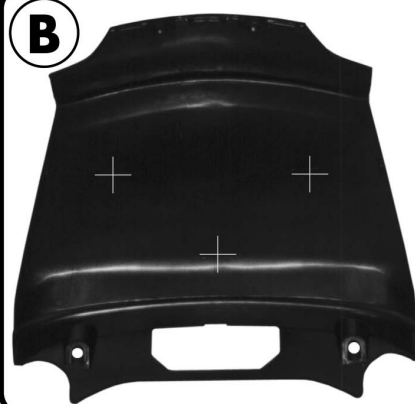

FORARE NEI TRE PUNTI INDICATI; FORARE PRIMA CON UNA PUNTA PICCOLA (Ø6), POI ALLARGARE I FORI ED ALL'OCCORRENZA CENTRARLI CON UNA PUNTA DA 16mm

PIERCE THE THREE POINTS MARKED; START WITH A SMALL POINT (Ø6) AND CHECK THE POINTS ARE LINED UP WITH THE ORIGINAL SCREWS BELOW; THEN ENLARGE THE HOLES WITH A Ø16 POINT

PERCER LES 3 POINTS INDIQUEES EN COMMENCANT AVEC UN FORET 6mm, VERIFIER QU'ILS SONT ALIGNED AVEC LES VIS ORIGINALES DESSOUS, POIS AGGRANDIR LES TROUS AVEC UN FORET DE 16mm

MIT EINEM 6mm BOHRER VORBOHREN; DANN ÜBERPRÜFEN OB DIE BOHRUGEN MIT DEN ORIGINALSCHRAUBEN MITTIG SIND; JETZT DIE LÖCHER AUF 16mm AUFBOHREN

AGUJEREAR EN LOS TRES PUNTOS INDICADOS; AGUJEREAR PRIMERO CON LA PUNTA PEQUEÑA (Ø6), CONTROLAR QUE COINCIDAN CON LOS TORNILLOS QUE SE ENCUENTRAN EN EL CHASIS DE LA MOTO, LUEGO AMPLIAR EL AGUJERO CON UNA PUNTA DE 16mm

### ATTENZIONE

PESO MASSIMO SOPPORTABILE DAL PORTAPACCO 6Kg.

### WARNING:

MAX. LOADING OF THE CARRIER 6Kg.(13lbs)

### ATTENTION

CHARGE MAXIMALE 6Kg.

### ACHTUNG

MAXIMALE BELASTUNG DES TRÄGERS 6Kg.

### ATENCIÓN

CARGA MÁXIMA AUTORIZADA DEL PORTAEQUIPAJE 6Kg.