

PORTAVALIGIA SPECIFICO - SPECIFIC CASE HOLDER
 PORTE-VALISE SPECIFIQUE - SPEZIFISCHER KOFFER-TRÄGER
 PORTA-EQUIPAJE ESPECIFICO

BMW R1150R '02/'03

ISTRUZIONI DI MONTAGGIO - MOUNTING INSTRUCTIONS
 INSTRUCTIONS DE MONTAGE - BAUANLEITUNG - INSTRUCCIONES DE MONTAJE

1 Z622



PIASTRA
 PLATE
 PLATINE
 PLATINA

Q.TY n.1

2

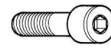

VITE TCEI M6x25mm
 SCREW M6x25mm
 VIS M6x25mm
 SCHRAUBE M6x25mm
 TORNILLO M6x25mm

Q.TY n.4

3



RONDELLA Ø6
 WASHER Ø6
 RONDELLE Ø6
 SCHEIBE Ø6
 ARANDELA Ø6

Q.TY n.20

4



DADO A.B. M6
 BOLT M6
 ECROU M6
 MUTTER M6
 TUERCA M6

Q.TY n.8

5



GOMMINO
 RUBBER
 CAOUTCHOUC
 GUMMI
 GOMA

Q.TY n.4

6



Z 621
COPRIFORO
 BOLT CAP
 CACHE TROU
 MUTTER STOPSEL
 TAPA AGUJERO

Q.TY n.6

7



Z 872

TAPPO ANTIFURTO
 ANTI-THFT CAP
 BOUCHON ANTIVOL
 ANTI-DIEBSTAHL
 TAPON ANTIRROBO

Q.TY n.1

8



SUPPORTO
 SUPPORT
 SUPPORT
 TRÄGER
 SOPORTE **GL747**

Q.TY n.2(dx-sx)

9



SUPPORTO
 SUPPORT
 SUPPORT
 TRÄGER
 SOPORTE

Q.TY n.2(dx-sx)

10



Z822

COPRIVITE Ø6
 SCREW CAP
 CACHE VIS
 STOPSSCHRAUBE
 TAPA TORNILLO

Q.TY n.4

11



8COP

COPRIDADO M6
 BOLT CAP
 CACHE ECROU
 STOPSMUTTER
 TAPA TUERCA

Q.TY n.4

12

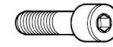

VITE TCEI M6x35mm
 SCREW M6x35mm
 VIS M6x35mm
 SCHRAUBE M6x35mm
 TORNILLO M6x35mm

Q.TY n.4

13

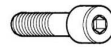

VITE TCEI M6x30mm
 SCREW M6x30mm
 VIS M6x30mm
 SCHRAUBE M6x30mm
 TORNILLO M6x30mm

Q.TY n.4

14

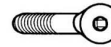

VITE TSCEI M6x16mm
 SCREW M6x16mm
 VIS M6x16mm
 SCHRAUBE M6x16mm
 TORNILLO M6x16mm

Q.TY n.2

15

COMPONENTI ORIGINALI
 ORIGINAL PARTS
 ORIGINAL BAUTEILE
 PARTIES ORIGINALES
 COMPONENTES ORIGINALES

Q.TY n.-

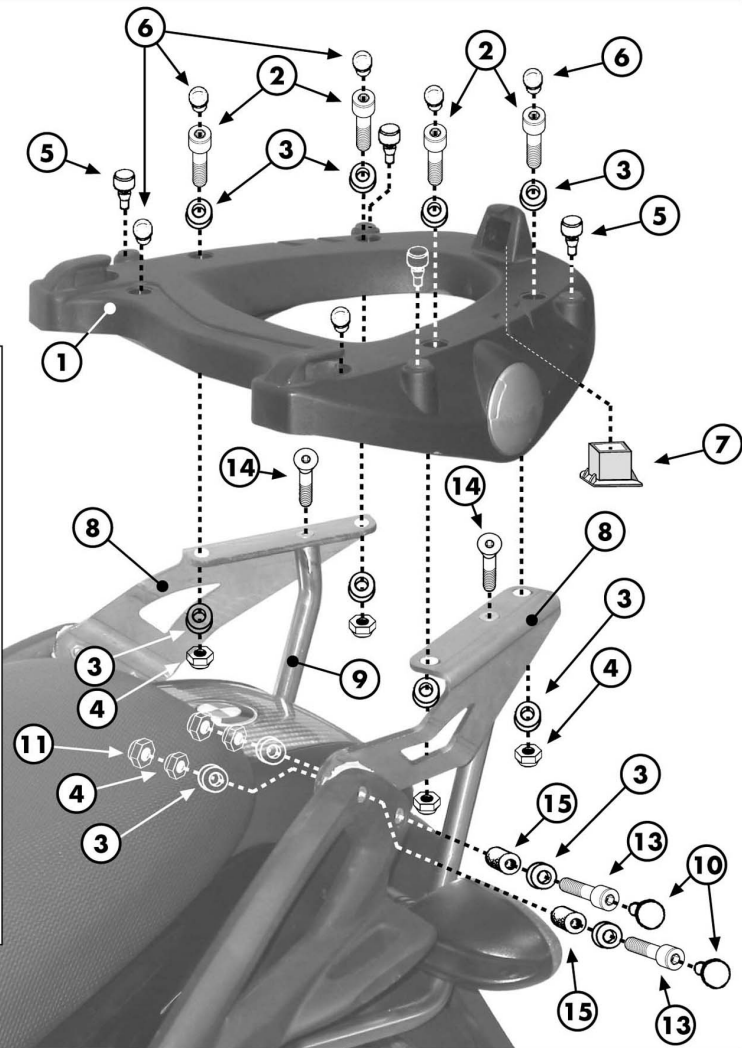

ATTENZIONE
 PESO MASSIMO
 SOPPORTABILE
 DAL
 PORTAPACCO
 10Kg.

WARNING
 MAX. LOADING
 OF THE CARRIER
 10Kg. (21lbs)

ATTENTION
 CHARGE
 MAXIMALE 10Kg.

ACHTUNG
 MAXIMALE
 BELASTUNG DES
 TRÄGERS 10Kg.

ATENCIÓN
 CARGA MÁXIMA
 AUTORIZADA DEL
 PORTAEQUIPAJE
 10Kg.

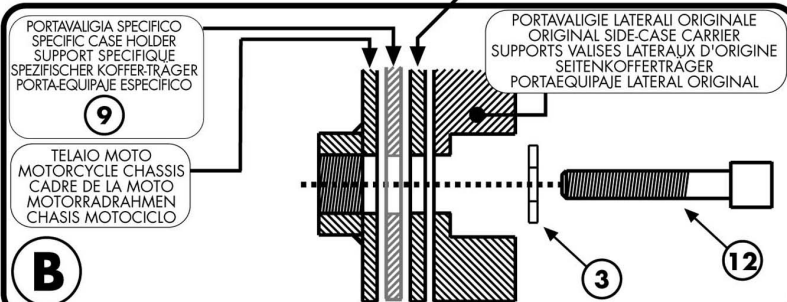
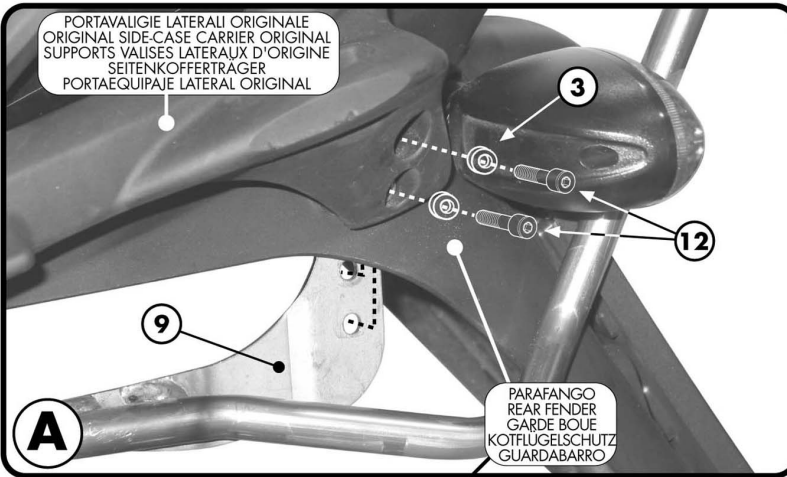

PORTAVALIGIA SPECIFICO - SPECIFIC CASE HOLDER
 PORTE-VALISE SPÉCIFIQUE - SPEZIFISCHER KOFFER-TRÄGER
 PORTA-EQUIPAJE ESPECIFICO

BMW R1150R '02/'03

ISTRUZIONI DI MONTAGGIO - MOUNTING INSTRUCTIONS
 INSTRUCTIONS DE MONTAGE - BAUANLEITUNG - INSTRUCCIONES DE MONTAJE

I ISTRUZIONI DI MONTAGGIO

1. ATTENZIONE: È INDISPENSABILE CHE SIA MONTATO IL PORTAVALIGE ORIGINALE BMW.
2. SMONTARE IL PORTAPACCHINO ORIGINALE BMW (SE MONTATO).
3. MONTARE I SUPPORTI N°9 COME INDICATO IN FOTO A E SCHEMATIZZATO NEL DISEGNO B.
4. MONTARE I SUPPORTI N°8 COME INDICATO IN FOTO C.
5. MONTARE LA PIASTRA N°1 COME INDICATO IN FOTO C.

E MOUNTING INSTRUCTIONS

1. ATTENTION: IT IS NECESSARY THAT THE ORIGINAL BMW SIDE-CASE HOLDER IS MOUNTED ON THE MOTORCYCLE.
2. REMOVE THE ORIGINAL BMW TOPCASE CARRIER (IF IT WAS MOUNTED).
3. NOW MOUNT THE SUPPORTS N°9 AS SHOWN IN PICTURE A AND SCHEMATISED IN DRAWING B.
4. MOUNT THE SUPPORTS N°8 AS SHOWN IN PICTURE C.
5. MOUNT THE PLATE N°1 AS SHOWN IN PICTURE C.

F INSTRUCTIONS DE MONTAGE

1. ATTENTION : IL EST INDISPENSABLE DE MONTER LE PORTE PAQUET AVEC LES SUPPORTS VALISES D'ORIGINE BMW.
2. DEMONTER LE PORTE PAQUET ORIGINAL BMW (SI MONTE).
3. MONTER LES SUPPORTS N9 COMME INDIQUE SUR LA PHOTO A ET SUR LE DESSIN B.
4. MONTER LES SUPPORTS N8 COMME INDIQUE SUR LA PHOTO C.
5. MONTER LA PLATINE N1 COMME INDIQUE SUR LA PHOTO C.

D BAUANLEITUNG

1. ACHTUNG: MONTAGE NUR MIT ORIGINAL SEITENKOFFERTRÄGER MÖGLICH.
2. FALLS DER ORIGINAL BMW TOPCASE TRÄGER VORHANDEN IST, ENTFERNEN SIE DEN TOPCASE TRÄGER.
3. MONTIEREN SIE DEN TRÄGER NR.°9 WIE ES IM FOTO A UND IN DER ZEICHNUNG B BESCHRIEBEN IST.
4. MONTIEREN SIE JETZT DEN TRÄGER NR.°8 GL747 WIE IM BILD C BESCHRIEBEN.
5. MONTIEREN SIE DIE PLATTE N°1 WIE IM FOTO D BESCHRIEBEN.

ES

INSTRUCCIONES DE MONTAJE

1. ATENCIÓN: ES INDISPENSABILE MONTAR EL PORTAMALETAS LATERAL ORIGINAL BMW
2. DESMONTAR EL PORTAEQUIPAJE ORIGINAL BMW (SI MONTADO)
3. MONTAR LOS SOPORTES NR 9, COMO EN LA FOTO A Y EN EL DIBUJO B
4. MONTAR LOS SOPORTES NR 8, COMO EN LA FOTO C
5. MONTAR LA PARRILLA NR 1, COMO EN LA FOTO C