

PORTAVALIGIE LATERALE SPECIFICO - SPECIFIC TUBULAR SIDE-CASE HOLDER
 PORTE-VALISES LATÉRAUX SPÉCIFIQUE - SPEZIFISCHES STAHLROHR-SEITENTRÄGER
 PORTA-EQUIPAJE LATERAL ESPECÍFICO

YAMAHA FZS1000 2003 FAZER

ISTRUZIONI DI MONTAGGIO - MOUNTING INSTRUCTIONS
 INSTRUCTIONS DE MONTAGE - BAUANLEITUNG - ISTRUCCIONES DE MONTAJE

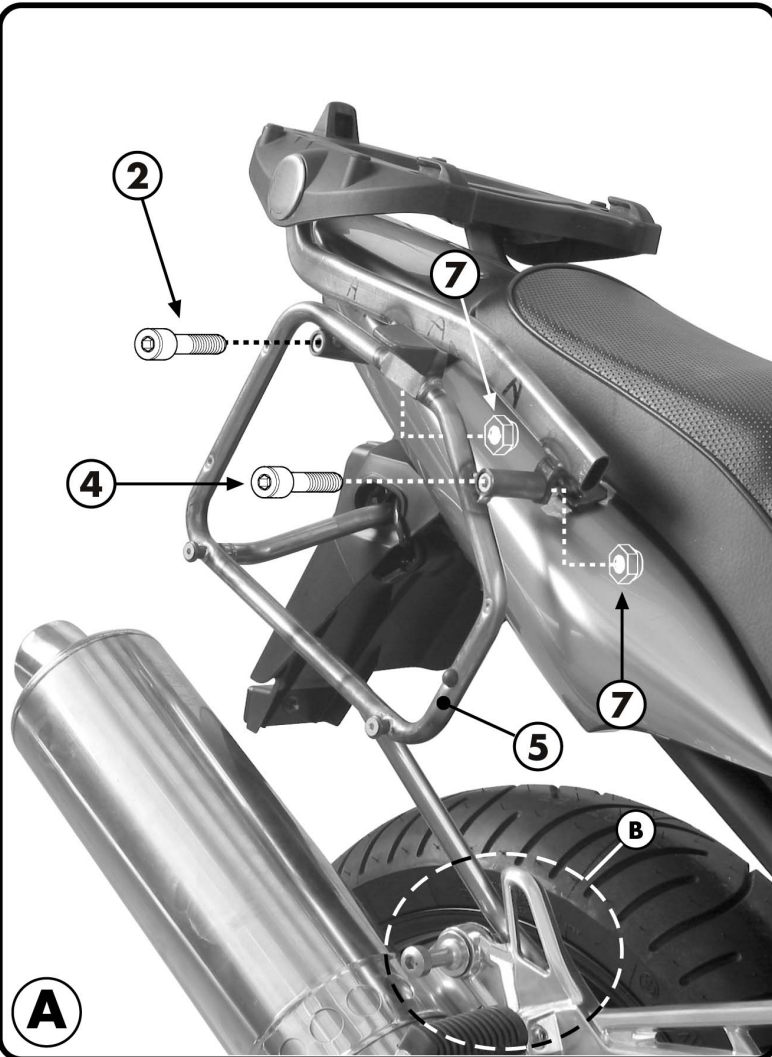
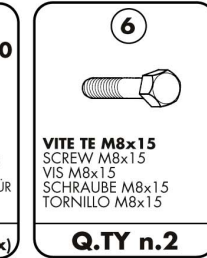
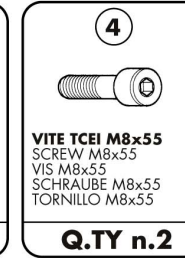
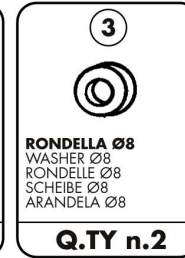
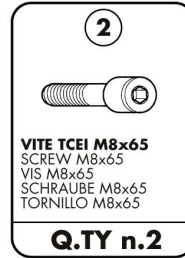
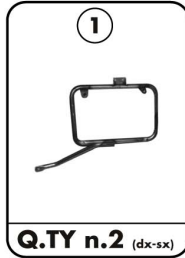

PRIMA di montare i portavaligia laterali é necessario aver **già** montato il portavaligia centrale

Before mounting the tubular side-case holder it is **necessary** to mount the top case carrier

Avant de monter les supports valises il est **nécessaire** de monter le porte paquet central

Bevor Sie die Seitenträger montieren, muß der Topcase Träger montiert werden

Montar el portamaletas central **ANTES** de montar los portamaletas laterales

ATTENZIONE
 GIVI CONSIGLIA L'UTILIZZO DELLE VALIGIE LATERALI E21

WARNING
 GIVI RECOMMENDS THE USE OF PANNIERS E21

ATTENTION
 GIVI CONSEILLE D'UTILISER LES VALISES LATÉRALES E21

ACHTUNG
 GIVI EMPFIEHLT DIE BENUTZUNG VON SEITENKOFFERN E21

ATENCION
 GIVI ACONSEJA DE UTILISAR LAS MALETAS E21

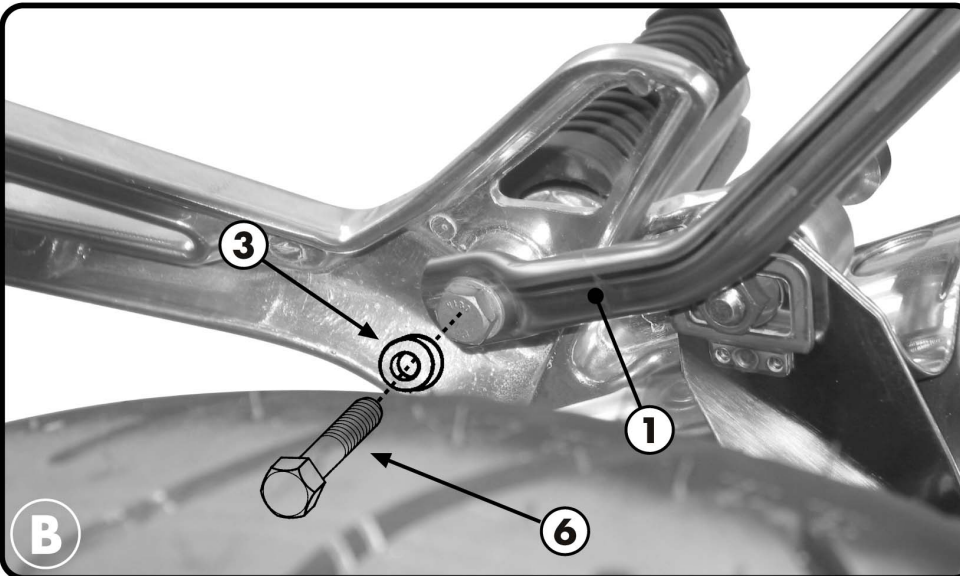

PORTAVALIGIE LATERALE SPECIFICO - SPECIFIC TUBULAR SIDE-CASE HOLDER
 PORTE-VALISES LATÉRAUX SPÉCIFIQUE - SPEZIFISCHES STAHLROHR-SEITENTRÄGER
 PORTA-EQUIPAJE LATERAL ESPECÍFICO

YAMAHA FZS1000 2003 FAZER

ISTRUZIONI DI MONTAGGIO - MOUNTING INSTRUCTIONS
 INSTRUCTIONS DE MONTAGE - BAUANLEITUNG - ISTRUCCIONES DE MONTAJE

7



DADO A.B. RIB. M8
 BOLT M8
 ECROU M8
 MUTTER M8
 TUERCA M8

Q.TY n.4

8



FUNGHETTO
 SIDE SUPPORT
 CRAMPILLON
 LAGER
 BRIDA

Q.TY n.2

9



VITE TCEI M6x40
 SCREW M6x40
 VIS M6x40
 SCHRAUBE M6x40
 TORNILLO M6x40

Q.TY n.2

10



PONTE POSTERIORE
 REAR BRIDGE
 PONT POSTÉRIEURE
 BRÜCKE
 PUENTE POSTERIOR

Q.TY n.1

11

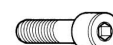

VITE TCEI M6x30
 SCREW M6x30
 VIS M6x30
 SCHRAUBE M6x30
 TORNILLO M6x30

Q.TY n.2

12



GL632
SUPPORTO FRECCIA
 BLINKER SUPPORT
 SUPPORT CLIGNOTANT
 LAGER BLINKER
 SOPORTE INTERMITENTE

Q.TY n.2 (dx-sx)

ATTENZIONE: CARICO MASSIMO, 3Kg. PER OGNI VALIGIA

WARNING: MAX LOAD, 3Kg. FOR SIDECASE

ATTENTION: CHARGE MAXIMUM, 3Kg. CHAQUE VALISE

ACHTUNG: MAX, 3Kg. PRO KOFFER

ATENCIÓN: CARGO MÁXIMO, 3Kg. POR CADA MALETA

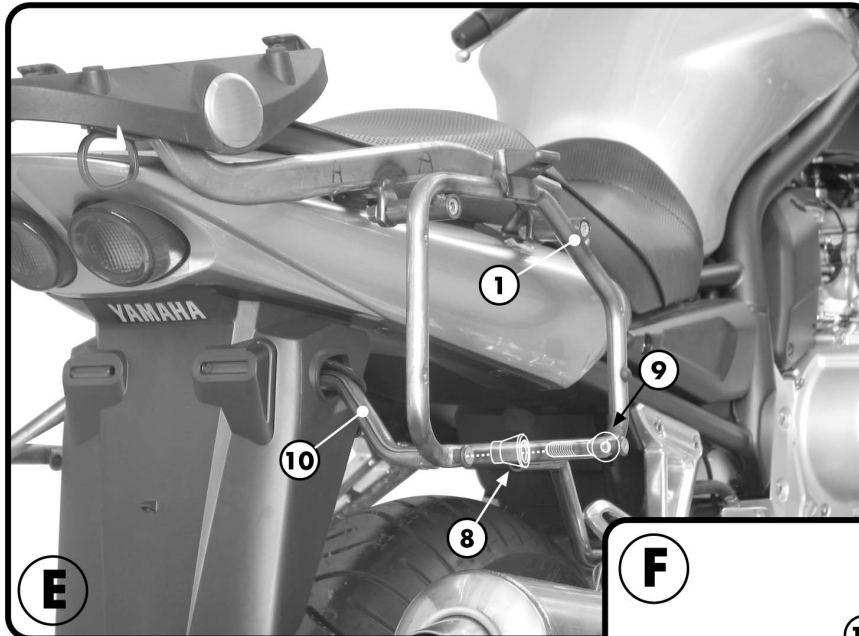

E

13

PARTICOLARI INCLUSI NEL KIT VITERIA DELLA PIASTRA
 COMPONENTS INCLUDED IN THE FITTING KIT OF THE PLATE
 PIÈCES INCLUSES DANS LE KIT DE VIS DE LA PLATINE
 DIE EINZELNEN TEILE SIND BEI MONTAGEKIT DER PLATTE ENTHALTEN
 PIEZAS INCLUIDAS EN EL KIT DE ANCLAJE DE LA PLETINA

Q.TY n.-

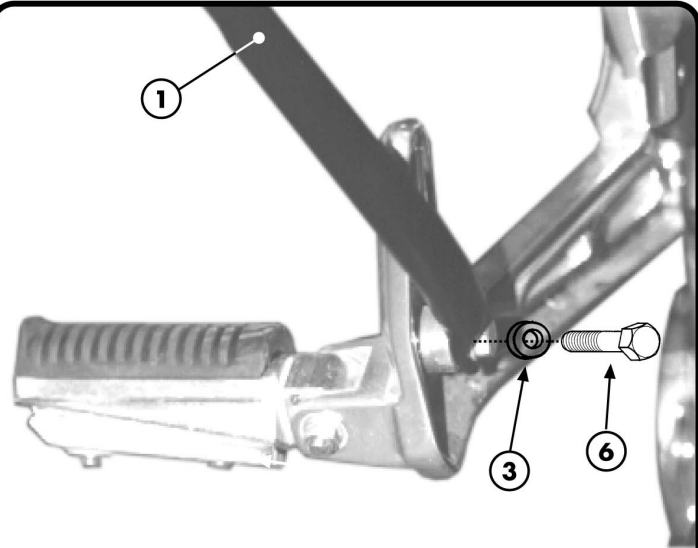

D

Parte Sinistra
 Left hand
 Côté gauche
 Linke seite
 Parte izquierda

UTILIZZARE LA PROLUNGA PER IL COLLEGAMENTO DELLE FRECCHE POSTERIORI ALL'IMPIANTO ELETTRICO DEL MOTOCICLO.
 USE THE WIRE EXTENSION TO CONNECT THE REAR INDICATORS WITH THE ELECTRICAL SYSTEM OF THE BIKE.
 UTILISER LE PROLONGATEUR POUR LA CONNECTION DES CLIGNOTANS POSTÉRIEURS DU SYSTÈME ÉLECTRIQUE DE LA MOTO
 VERWENDEN SIE DAS VERLÄNGERUNGSKABEL UM DIE HINTEREN BLINKER MIT DER ELEKTRISCHEN ANLAGE DES MOTORRADES ZU VERBINDEN.
 USAR EL ALARGUE PARA CONECTAR LAS FLECHAS POSTERIORES A LA INSTALACIÓN ELÉCTRICA DE LA MOTOCICLETA

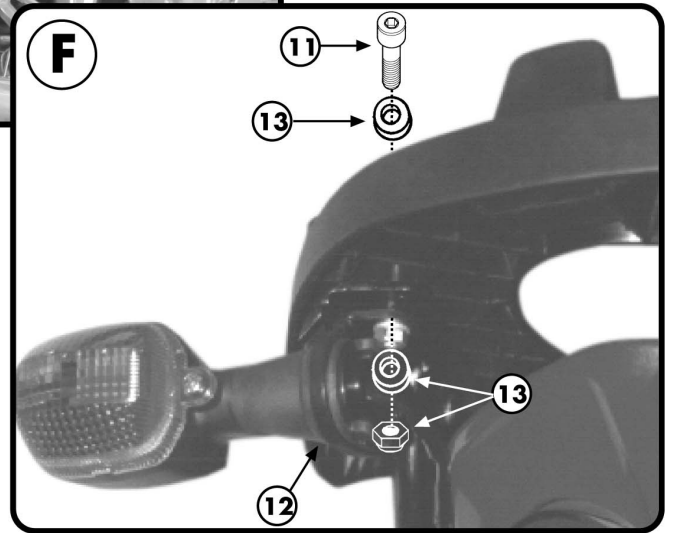

F