

PORTAVALIGIE LATERALE SPECIFICO - SPECIFIC TUBULAR SIDE-CASE HOLDER  
 PORTE-VALISES LATÉRAUX SPÉCIFIQUE - SPEZIFISCHES STAHLROHR-SEITENTRAEGER  
 PORTA MALETAS LATERALES ESPECIFICO

# BMW R1200GS 2004

ISTRUZIONI DI MONTAGGIO - MOUNTING INSTRUCTIONS  
 INSTRUCTIONS DE MONTAGE - BAUANLEITUNG - INSTRUCCIONES DE MONTAJE

①  
  
**SUPPORTO**  
 SUPPORT  
 SUPPORT  
 HALTER  
 SOPORTE  
**Q.TY n.2(Dx-Sx)**

②  
  
**PONTE POSTERIORE**  
 REAR BRIDGE  
 PONT POSTERIEURE  
 VERBINDUNGSROHR  
 PUENTE TRASERO  
**Q.TY n.1**

③  
  
**VITE TCEI M6x15mm**  
 SCREW M6x15mm  
 VIS M6x15mm  
 SCHRAUBE M6x15mm  
 TORNILLO M6x15mm  
**Q.TY n.2**

④  
  
**VITE TCEI M6x60mm**  
 SCREW M6x60mm  
 VIS M6x60mm  
 SCHRAUBE M6x60mm  
 TORNILLO M6x60mm  
**Q.TY n.2**

⑤  
  
**VITE TCEI M6x50mm**  
 SCREW M6x50mm  
 VIS M6x50mm  
 SCHRAUBE M6x50mm  
 TORNILLO M6x50mm  
**Q.TY n.2**

⑥  
  
**VITE TBEI M8x55mm**  
 SCREW M8x55mm  
 VIS M8x55mm  
 SCHRAUBE M8x55mm  
 TORNILLO M8x55mm  
**Q.TY n.2**

⑦  
  
**RONDELLA Ø8x14mm**  
 WASHER Ø8x14mm  
 RONDELLE Ø8x14mm  
 SCHEIBE Ø8x14mm  
 ARANDELA Ø8x14mm  
**Q.TY n.4**

⑧  
  
**RONDELLA Ø8mm**  
 WASHER Ø8mm  
 RONDELLE Ø8mm  
 SCHEIBE Ø8mm  
 ARANDELA Ø8mm  
**Q.TY n.2**

⑨  
  
**DADO A.B. M8**  
 BOLT M8  
 ECROU M8  
 MUTTER M8  
 TUERCA M8  
**Q.TY n.2**

⑩  
  
**DADO M8**  
 BOLT M8  
 ECROU M8  
 MUTTER M8  
 TUERCA M8  
**Q.TY n.2**

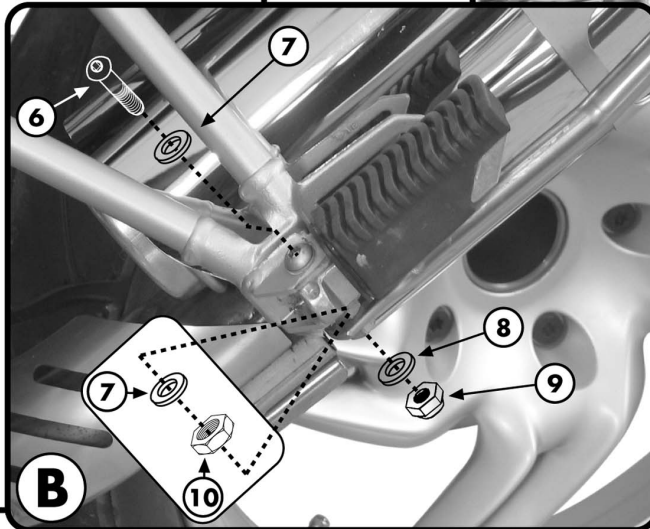
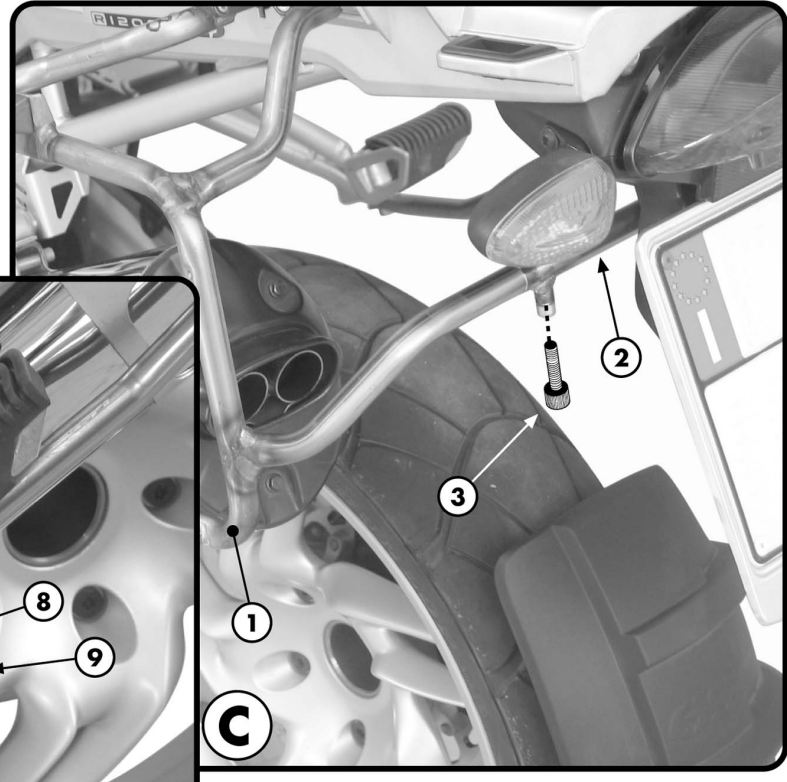
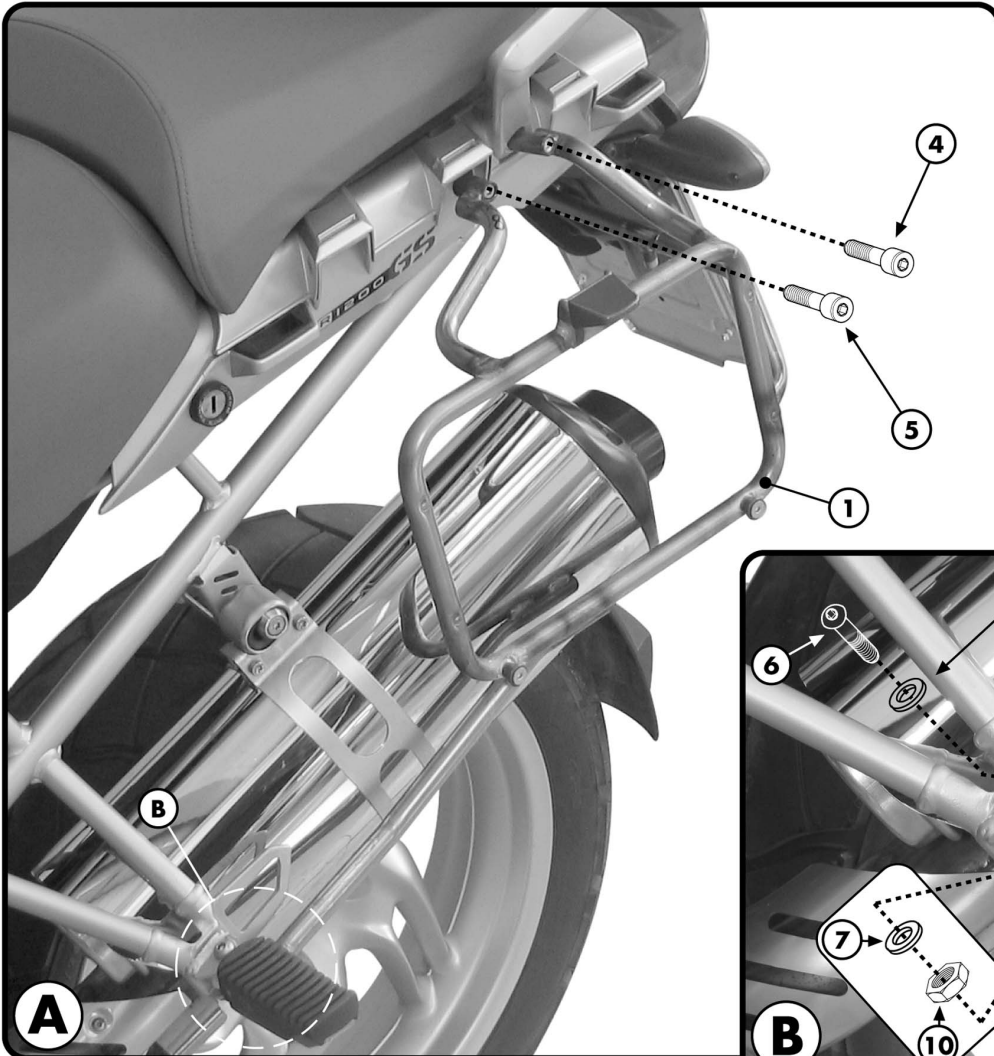

PL684 - KL684

PORTAVALIGIE LATERALE SPECIFICO - SPECIFIC TUBULAR SIDE-CASE HOLDER  
PORTE-VALISES LATÉRAUX SPÉCIFIQUE - SPEZIFISCHES STAHLROHR-SEITENTRÄGER  
PORTA MALETAS LATERALES ESPECIFICO

**BMW R1200GS 2004**

ISTRUZIONI DI MONTAGGIO - MOUNTING INSTRUCTIONS  
INSTRUCTIONS DE MONTAGE - BAUANLEITUNG - INSTRUCCIONES DE MONTAJE

## I ISTRUZIONI DI MONTAGGIO

1. MONTARE IL PORTAVALIGIA LATERALE COME INDICATO IN FOTO A;
2. FISSARE IL PORTAVALIGIA ALLA PEDALINA DEL PASSEGGERO COME INDICATO IN FOTO B;
3. COLLEGARE LA PARTE DESTRA CON LA SINISTRA MONTANDO IL PONTE POSTERIORE DI COLLEGAMENTO N°2 COME INDICATO IN FOTO C;
4. ULTIMARE IL MONTAGGIO CONTROLLANDO CHE TUTTE LE VITI SIANO SERRATE BENE.

## GB MOUNTING INSTRUCTIONS

1. MOUNT THE SIDE CASE HOLDER AS SHOWN IN PICTURE A;
2. FIX THE SUPPORT TO THE PASSENGER'S FOOTREST AS SHOWN IN PICTURE B;
3. CONNECT THE LEFT SIDE TO THE RIGHT SIDE OF THE HOLDER USING THE REAR BRIDGE N° 2 AS SHOWN ON PICTURE C;
4. LASTLY CHECK THAT ALL SCREWS HAVE BEEN TIGHTENED.

## F INSTRUCTIONS DE MONTAGE

1. MONTER LES SUPPORTS VALISES COMME INDIQUE SUR LA PHOTO A;
2. FIXER LES SUPPORTS VALISES AUX REPOSE-PIEDS PASSAGER COMME INDIQUE SUR LA PHOTO B;
3. UNIR LA PARTIE GAUCHE A LA PARTIE DROITE EN MONTANT LE PONT POSTERIEUR DE JONCTION N°2 COMME INDIQUE SUR LA PHOTO C;
4. TERMINER LE MONTAGE EN SERRANT BIEN TOUTES LES VIS.

## D BAUANLEITUNG

1. MONTIEREN SIE DEN SEITENKOFFERTRÄGER WIE IM BILD A BESCHRIEBEN;
2. BEFESTIGEN SIE DEN SEITENKOFFERTRÄGER AN DEN BEIFÄHRER-FUßRASTEN WIE IM BILD B BESCHRIEBEN;
3. VERBINDEN SIE DAS LINKE TEIL DES SEITENTRÄGERS MIT DER RECHTEN MIT DEM VERBINDUNGSROHR NR. 2 WIE IM BILD 2 BESCHRIEBEN;
4. ZULETZT ZIEHEN SIE ALLE SCHRAUBEN FEST.

ES

## INSTRUCCIONES DE MONTAJE

1. MONTAR EL PORTA MALETAS LATERAL COMO INDICA LA FOTO A;
2. ANCLAR EL PORTAMALETAS A LA ESTRIBERA DEL PASAJERO COMO INDICA LA FOTO B;
3. UNIR LA PARTE DERECHA CON LA IZQUIERDA MONTANDO EL PUENTE TRASERO DE CONEXIÓN N° 2 COMO INDICA LA FOTO C;
4. TERMINAR APRETANDO TODOS LOS TORNILLOS