

PORTAVALIGIE LATERALE SPECIFICO - SPECIFIC TUBULAR SIDE-CASE HOLDER
 PORTE-VALISES LATÉRAUX SPÉCIFIQUE - SPEZIFISCHES STAHLROHR-SEITENTRAEGER
 PORTA MALETAS LATERALES ESPECÍFICO

DUCATI MULTISTRADA 1200cc

2010 - 2013

ISTRUZIONI DI MONTAGGIO - MOUNTING INSTRUCTIONS
 INSTRUCTIONS DE MONTAGE - BAUANLEITUNG - INSTRUCCIONES DE MONTAJE

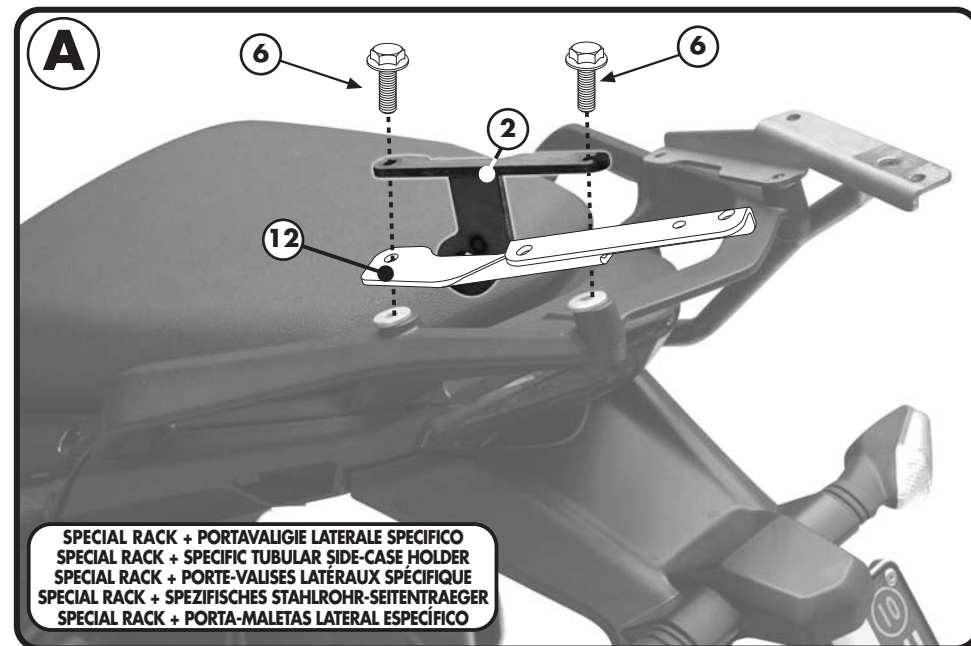
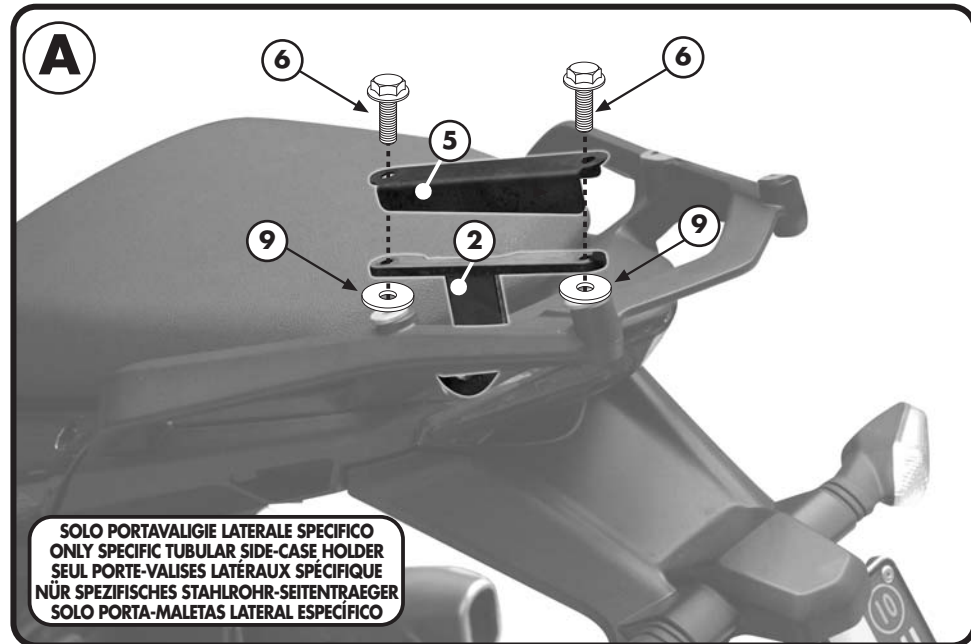
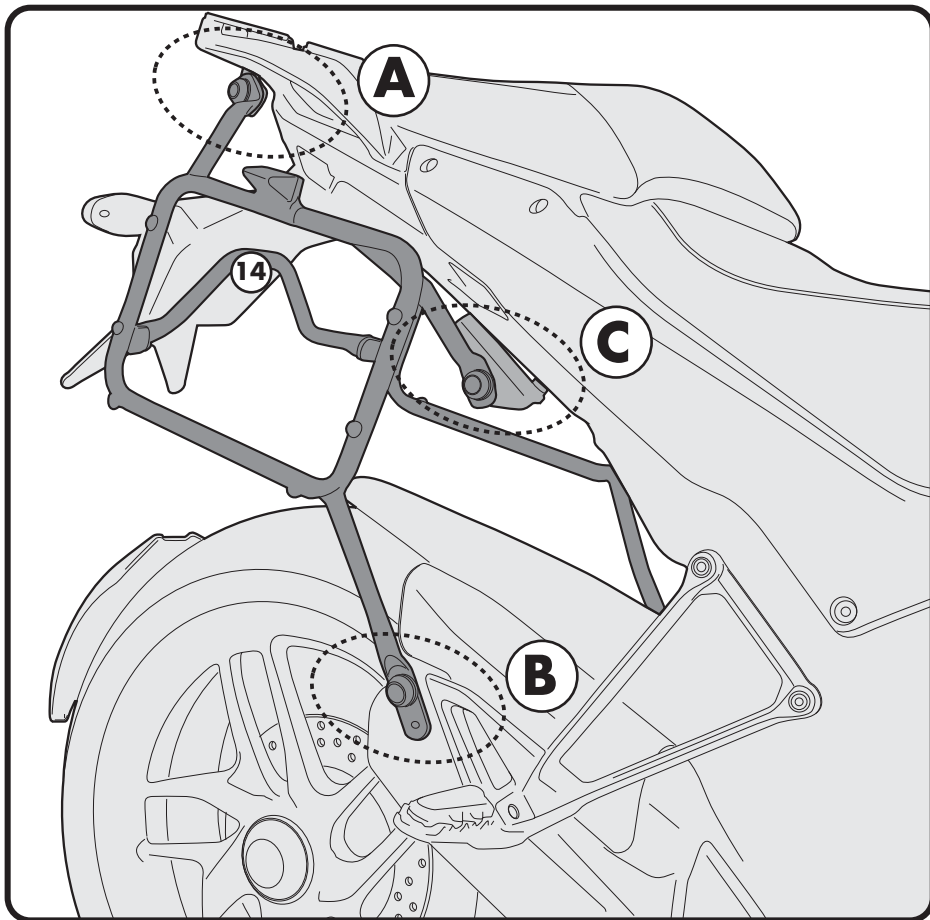
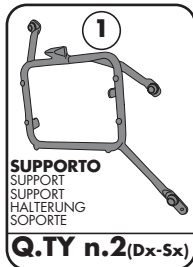

PORTAVALIGIE LATERALE SPECIFICO - SPECIFIC TUBULAR SIDE-CASE HOLDER
 PORTE-VALISES LATÉRAUX SPÉCIFIQUE - SPEZIFISCHES STAHLROHR-SEITENTRÄGER
 PORTA MALETAS LATERALES ESPECÍFICO

DUCATI MULTISTRADA 1200cc

2010 - 2013

ISTRUZIONI DI MONTAGGIO - MOUNTING INSTRUCTIONS
 INSTRUCTIONS DE MONTAGE - BAUANLEITUNG - INSTRUCCIONES DE MONTAJE

6



VITE TEF M6x20mm
 SCREW
 VIS
 SCHRAUBE
 TORNILLO

Q.TY n.4

7



VITE TEF M6x35mm
 SCREW
 VIS
 SCHRAUBE
 TORNILLO

Q.TY n.4

8



VITE TCEI M6x25mm
 SCREW
 VIS
 SCHRAUBE
 TORNILLO

Q.TY n.4

9



DISTANZIALE Ø20x3mm
 Foro Ø6,5mm, V244
 SPACER
 ENTRETÔISE
 DISTANZSTÜCK
 DISTANCIADOR

Q.TY n.4

10



DISTANZIALE Ø16x3mm
 Foro Ø6,5mm, V263
 SPACER
 ENTRETÔISE
 DISTANZSTÜCK
 DISTANCIADOR

Q.TY n.4

11



V 775

DISTANZ. Ø15x13.8
 Rib. Ø 10x4, foro 7
 SPACER
 ENTRETÔISE
 DISTANZSTÜCK
 DISTANCIADOR

Q.TY n.4

12

PARTICOLARI INCLUSI NELL'SR
 COMPONENTS INCLUDED IN THE FITTING KIT OF THE SR
 PIÉCES INCLUES DANS LE KIT DE VIS DE EL SR
 DIE EINZELNEN TEILE SIND BEI MONTAGEKIT DER SR ENTHALTEN
 DESPIECES INCLUIDOS EN EL KIT DE ANCLAJES DE EL SR

Q.TY n.-

13



CHIAVE PER VITI A TESTA SPECIALE
 SPECIAL KEY
 CLÉ SPECIALE
 SPEZIALSCHLÜSSEL ZUR DEMONTAGE DES TRÄGERS
 LLAVE PARA TORNILLOS CON CABEZA ESPECIAL

Q.TY n.1

14



PONTE POSTERIORE
 REAR BRIDGE
 POINT POSTÉRIEURE
 VERBINDERINGSROHR
 PUENTE TRASERO

Q.TY n.1

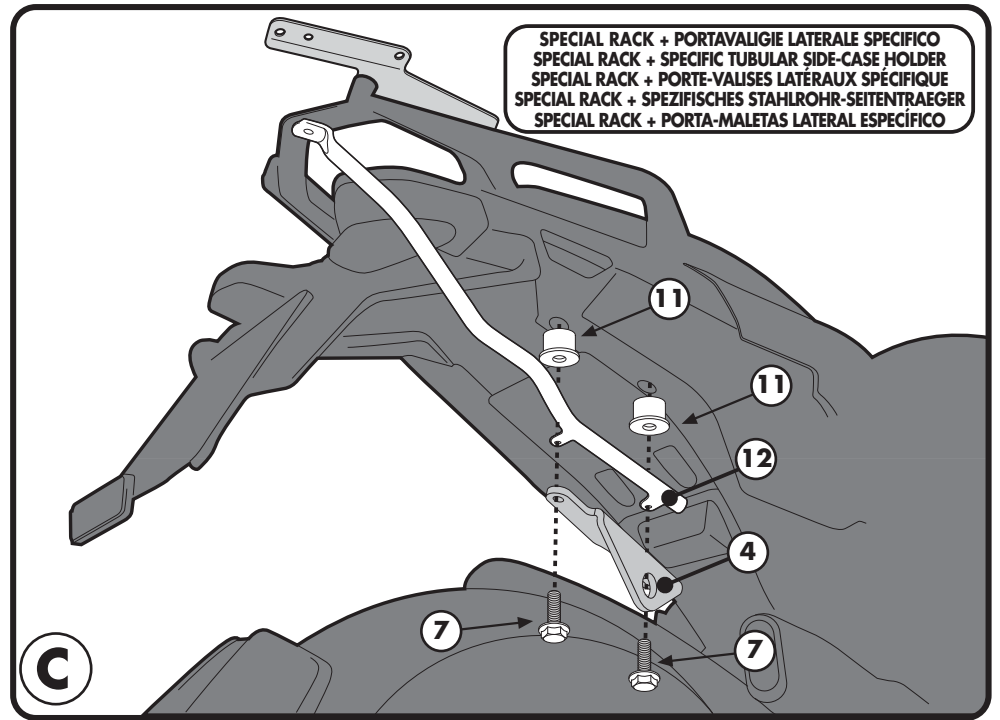
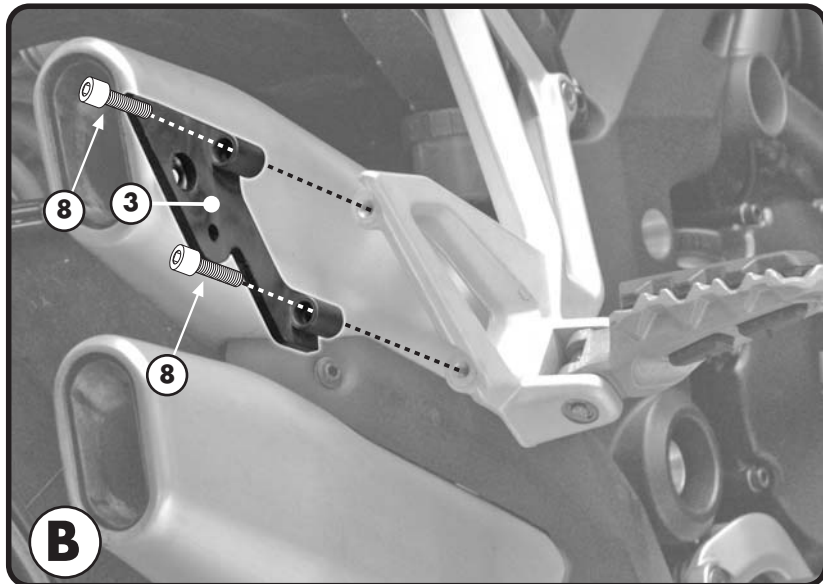

SPECIAL RACK + PORTAVALIGIE LATERALE SPECIFICO
 SPECIAL RACK + SPECIFIC TUBULAR SIDE-CASE HOLDER
 SPECIAL RACK + PORTE-VALISES LATÉRAUX SPÉCIFIQUE
 SPECIAL RACK + SPEZIFISCHES STAHLROHR-SEITENTRÄGER
 SPECIAL RACK + PORTA-MALETAS LATERAL ESPECÍFICO

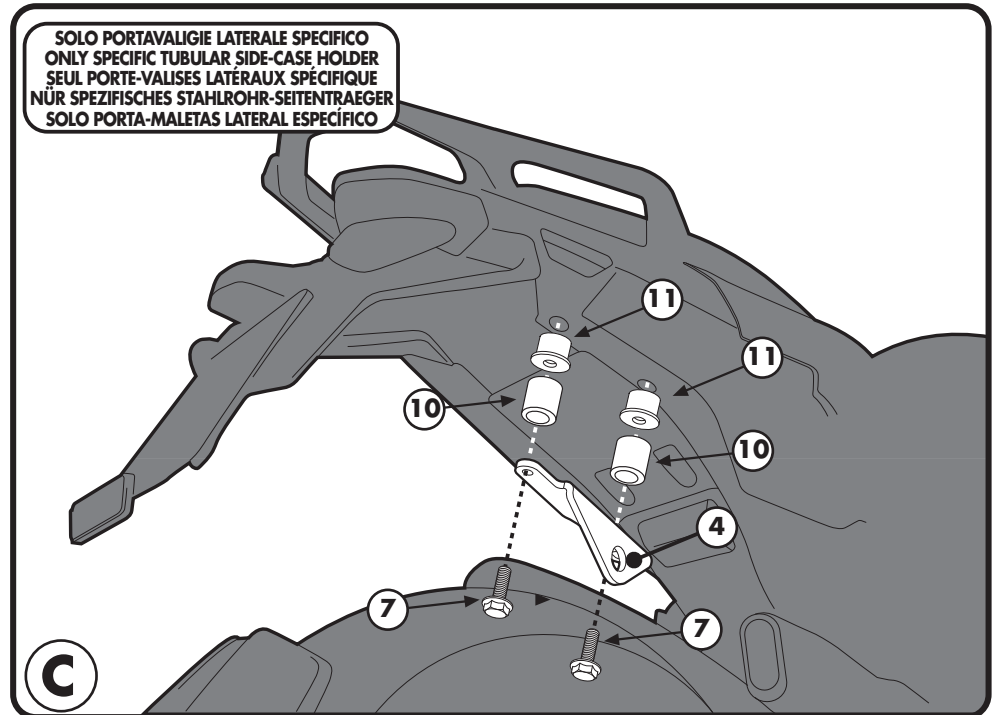

SOLO PORTAVALIGIE LATERALE SPECIFICO
 ONLY SPECIFIC TUBULAR SIDE-CASE HOLDER
 SEUL PORTE-VALISES LATÉRAUX SPÉCIFIQUE
 NÜR SPEZIFISCHES STAHLROHR-SEITENTRÄGER
 SOLO PORTA-MALETAS LATERAL ESPECÍFICO

MONTAGGIO / SMONTAGGIO PORTAVALIGE LATERALE VERSIONE PLXR "RAPID"



I

1. INSERIRE L'ATTREZZO NELLA TESTA DELLA VITE SPECIALE;
2. RUOTARE DI 1/4 DI GIRO IN SENSO ORARIO FINO A CHE LA ROTAZIONE NON TERMINA E SI AVVERTE LO SCATTO;
3. PER SMONTARE PROCEDERE IN SENSNO INVERSO.

GB

1. INSERT THE SPECIAL KEY INTO THE HEAD OF THE SCREW;
2. TURN THE KEY ¼ TURN CLOCKWISE UNTIL ROTATION STOPS AND THE SIDE CASE HOLDER IS FASTENED SECURELY TO THE FITMENT POINT;
3. IN ORDER TO DISASSEMBLE THE BRACKETRY PERFORM THE OPERATION IN REVERSE.

F

1. INSERER LA CLE SPECIALE DANS LA TETE DE LA VIS;
2. VISSER D'1/4 DE TOUR DANS LE SENS HORAIRE JUSQU'AU BLOCAGE DE LA VIS POUR MONTER EN TOUTE SECURITE LE SUPPORT A SON POINT DE FIXATION;
3. POUR LE DEMONTAGE, PROCEDER EN SENSE INVERSE.

D

1. STECKEN SIE DAS WERKZEUG IN DEN KOPF DER SPEZIFISCHEN SCHRAUBE;
2. DREHEN SIE DIE SCHRAUBE 1 / 4 UMDREHUNG IM UHRZEIGERSINN BIS SIE BEMERKEN, DASS DIE SCHRAUBE IM BEFESTIGUNGSPUNKT EINGEKLEMMT IST;
3. FÜR DIE DEMONTAGE FOLGEN SIE DEN HINWEISE UMGEKEHRT.

ES

1. INSERTAR LA LLAVE ESPECIAL EN LA CABEZA DEL TORNILLO
2. DAR ¼ DE VUELTA EN EL SENTIDO HORARIO HASTA QUE LLEGUE AL TOPE Y SE VEA EL TORNILLO;
3. PARA DESMONTARLO PROCEDER EN LA DIRECCIÓN CONTRARIA;



FORO DI SICUREZZA

FORO PREDISPOSTO AD ASSICURARE IL PORTAVALIGE LATERALE ALLA MOTO (CON UN LUCCHETTO PER ESEMPIO, NON INCLUSO).

SECURITY HOLE

HOLE PLACEMENT IN ORDER TO INCREASE SECURITY OF THE TUBULAR SIDE-CASE HOLDER TO THE MOTORCYCLE (WITH A LOCK, FOR EXAMPLE, NOT INCLUDED).

TROU DE SECURITE

TROU PREDISPOSE POUR ASSURER LE PORTE-VALISE LATERAL A LA MOTO (AVEC UN CADENAS PAR EXEMPLE, NON INCLUS).

SICHERHEITSLOCH

VORGESEHENES LOCH UM DEN SEITENKOFFER TRÄGER AN DEM FAHRZEUG ZU SICHERN (Z. B. MIT EINEM VORHÄNGESCHLOSS, NICHT ENTHALTEN);

ORIFICIO DE SEGURIDAD

ESTE ORIFICIO ESTÁ CREADO PARA ASEGURAR EL PORTAEQUIPAJES LATERAL A LA MOTO (POREJEMPLO CON UN CANDADO, QUE NO ESTÁ INCLUIDO).



4